



# **RNS<sup>®</sup> System Programming Manual**

**For the RNS<sup>®</sup> Tablet Model 5000 and the  
Patient Data Management System (PDMS) Model 4340**

**R<sub>X</sub>Only**

© 2024 NeuroPace, Inc.

DN 1018834 Rev 4  
Rev Date: 2024-09

## **ABOUT THIS MANUAL**

### **This manual includes instructions for use for:**

- The RNS<sup>®</sup> Tablet model 5000 with software version 1.9
- The NeuroPace<sup>®</sup> Patient Data Management System model 4340

*Note: The RNS<sup>®</sup> Tablet model 5000 is compatible with the RNS<sup>®</sup> Neurostimulator model RNS-300M and model RNS-320.*

*Note: The term “programmer” as used in this manual is a generic term that refers to the RNS<sup>®</sup> Tablet.*

*Note: Images in this manual are representative and may vary in detail from what a particular user experiences.*

## **FCC INFORMATION**

The following is communications regulation information on the neurostimulator models RNS-300M and RNS-320, and wand model W-02.

- Neurostimulator model RNS-300M FCC ID: WBWRF300
- Neurostimulator model RNS-320 FCC ID: WBWRF320
- Wand FCC ID: WBW5200 or WBW902

These components comply with Part 15 of the FCC Rules. Operation is subject to the following two conditions: (1) These devices may not cause harmful interference, and (2) these devices must accept any interference received, including interference that may cause undesired operation.

**IMPORTANT:** Changes or modifications to these components not expressly approved by NeuroPace, Inc. could void the FCC Certification, and negate your authority to operate them.

This equipment complies with FCC radiation exposure limits set forth for an uncontrolled environment. This transmitter must not be co-located or operating in conjunction with any other antenna or transmitter.

---

**SYMBOLS**

Explanation of symbols on product or package labeling



Caution



Do Not Resterilize



MR Conditional



MR Unsafe



Prescription Only



Non-Pyrogenic



Single Use



Sterilized Using Ethylene Oxide



Use

Temperature limits during use



Storage

Temperature limits during storage or transport



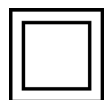
Manufacturer



Serial number



Type BF applied part



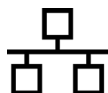
Class II electrical protection

5 V, 0.5 A

Direct current (DC) 5 V (volts), 0.5 A (amperes)

**IP22**

Ingress protection ratings: Level 2 for solid objects, which means testing confirms the device enclosure prevents ingress (entry) of items greater than 12.5 mm (~1/2 inch), such as fingers or similar objects; Level 2 for liquids, which means testing confirms vertically dripping water shall have no harmful effect when the enclosure is tilted at an angle up to 15° from its normal position.



Ethernet Connection (Network Connection)

Proposition 65, a State of California voter initiative, requires the following notice:



**WARNING:** This product can expose you to chemicals including ethylene oxide, which is known to the State of California to cause cancer and birth defects or other reproductive harm. For more information go to [www.P65Warnings.ca.gov](http://www.P65Warnings.ca.gov).

---

## TABLE OF CONTENTS

<b>ABOUT THIS MANUAL</b> .....	<b>II</b>
<b>FCC INFORMATION</b> .....	<b>III</b>
<b>SYMBOLS</b> .....	<b>IV</b>
<b>INTRODUCTION</b> .....	<b>4</b>
<b>DEVICE DESCRIPTION</b> .....	<b>4</b>
<b>RNS® TABLET</b> .....	<b>4</b>
<b>NEUROPACE® PATIENT DATA MANAGEMENT SYSTEM</b> .....	<b>4</b>
<b>PRODUCTS AND ACCESSORIES</b> .....	<b>4</b>
<b>CONTACTING NEUROPACE</b> .....	<b>5</b>
<b>TYPOGRAPHIC CONVENTIONS</b> .....	<b>5</b>
<b>WARNINGS AND CAUTIONS – PROGRAMMER</b> .....	<b>6</b>
<b>STERILIZATION AND STORAGE</b> .....	<b>8</b>
Product Storage .....	8
Explant and Disposal.....	8
Return / Disposal of Programmer and Wand.....	9
Wand Maintenance, Cleaning and Sterilization .....	9
Electrostatic Discharge (ESD) / Static Electricity .....	9
<b>RNS® TABLET INSTRUCTIONS</b> .....	<b>10</b>
<b>POWER ON THE TABLET</b> .....	<b>10</b>
<b>CONNECT AND LOGIN OVERVIEW</b> .....	<b>10</b>
<b>FUNCTIONALITY WITH AND WITHOUT A PDMS CONNECTION</b> .....	<b>11</b>
<b>CONNECT TO THE INTERNET FOR PDMS ACCESS</b> .....	<b>11</b>
Mobile Broadband Works Automatically.....	12
Steps to Connect to a Wi-Fi Network .....	12
If You Lose Network Connectivity .....	13
<b>LOG IN TO THE RNS® TABLET</b> .....	<b>14</b>
<b>NEUROPACE UPDATE CENTER</b> .....	<b>15</b>
Update Types.....	15
Update Options .....	15
Update Process and Power Requirements .....	16
<b>START SCREEN</b> .....	<b>17</b>
<b>LOG IN TO THE PDMS</b> .....	<b>18</b>
<b>INTERROGATE THE RNS® NEUROSTIMULATOR</b> .....	<b>19</b>
<b>PROGRAMMING OVERVIEW: RECORDING MONTAGE AND PROGRAMMING SETS</b> .....	<b>20</b>
Recording Montage .....	20
Programming Sets .....	20
Preparing Programming Sets on the PDMS vs. within an Interactive Programming Session.....	20
<b>DATA RETENTION AND ACCESS ON THE NEUROSTIMULATOR, PROGRAMMER AND PDMS</b> ..	<b>21</b>

---

Programmed Settings and Programming Sets .....	21
Storage of ECoGs and Neurostimulator Activity (Diagnostics).....	21
<b>HOME SCREEN .....</b>	<b>22</b>
<b>NEUROSTIM INFO SCREEN .....</b>	<b>24</b>
MRI Mode for RNS Neurostimulator Model RNS-320.....	26
Electrode Impedance and Battery Voltage.....	27
<b>ACTIVITY SCREEN .....</b>	<b>28</b>
Activity Histogram Viewing Options .....	30
View Neurostim Settings .....	31
View Event List .....	34
Types of Reports.....	34
Advanced Views.....	35
<b>ECoG LIBRARY SCREEN.....</b>	<b>35</b>
<b>LIVE ECoGs SCREEN .....</b>	<b>37</b>
<b>CREATE THE RECORDING MONTAGE .....</b>	<b>38</b>
Identifying Ports, Leads and Electrodes on the Neurostimulator.....	38
Creating the Montage.....	39
Recommended Initial Montage Settings.....	41
Program the Neurostimulator with the New Settings .....	41
<b>SET UP ECoG CAPTURE .....</b>	<b>43</b>
Selecting ECoG Capture Settings.....	43
Recommended Initial ECoG Capture Settings .....	46
Program the Neurostimulator with the New Settings .....	47
<b>RECOMMENDATION FOR REVIEW OF INITIAL ECoG CAPTURE SETTINGS .....</b>	<b>48</b>
<b>CONFIGURE DETECTION: DEFINE AND MODIFY DETECTION SETTINGS .....</b>	<b>49</b>
Phase 1: Select Default Detection Settings upon First Use .....	50
Phase 2: Define Detection Settings .....	53
Phase 3: Customize Detection.....	58
<b>DETECTION TOOLS AND DETECTORS .....</b>	<b>64</b>
Detection Tools and Detectors.....	64
Power Change Detector .....	65
Rhythmic Activity Detector.....	67
Spike Activity Detector .....	68
Bandpass Detection Tool .....	69
Area Detection Tool.....	70
<b>SHARE AND/OR DOWNLOAD A PROGRAMMING SET.....</b>	<b>71</b>
Steps to Share a Programming Set .....	72
Steps to Download a Programming Set to the Tablet for Offline Use.....	74
<b>OVERVIEW OF RESPONSIVE THERAPY .....</b>	<b>77</b>
<b>CONFIGURE RESPONSIVE THERAPY.....</b>	<b>78</b>
Optional Advanced Settings .....	82
Test Stimulation Before Enabling.....	84
Enable Therapy: Program RNS .....	85
Recommended Initial Responsive Therapy Settings .....	86
Recommended Therapy Modifications After Observing Clinical Response .....	87
<b>EXPORT AND IMPORT DEVICE SETTINGS FOR NEUROSTIMULATOR REPLACEMENT .....</b>	<b>88</b>

---

Transfer Compatibility .....	88
Export Neurostimulator Settings .....	88
Import Neurostimulator Settings .....	89
<b>PATIENT LIST ON TABLET AND THE PDMS ON A PERSONAL COMPUTER .....</b>	<b>91</b>
<b>PDMS ACCESS ON A PERSONAL COMPUTER.....</b>	<b>92</b>
<b>PDMS PROFILE AND SETTINGS .....</b>	<b>92</b>
<b>PATIENT &amp; NEUROSTIM INFO .....</b>	<b>95</b>
<b>PROGRAMMING.....</b>	<b>96</b>
<b>ACTIVITY .....</b>	<b>96</b>
<b>ECoG LIBRARY .....</b>	<b>96</b>
<b>LIVE ECoGs .....</b>	<b>96</b>
<b>PATIENT FOLLOW-UP ACTIVITIES.....</b>	<b>97</b>
<b>TROUBLESHOOTING.....</b>	<b>98</b>
Network Connectivity Problems .....	98
Abnormal Lead Impedance (greater than 3500 Ohms or less than 250 Ohms).....	98
Insufficient Charge .....	101
Noise, Artifacts, Poor Signal Displayed, or No Signal Displayed in Live ECoG .....	101
Poor or No Communication Between the RNS <sup>®</sup> Neurostimulator and the RNS <sup>®</sup> Tablet .....	102
Tablet Does Not Turn On .....	103
Tablet Freezes or Does Not Turn Off.....	103
Tablet Shuts Down.....	103
Impedance Measurement Was Rejected / Test Request Was Rejected .....	103
<b>SPECIFICATIONS AND CHARACTERISTICS .....</b>	<b>104</b>
<b>RNS<sup>®</sup> TABLET.....</b>	<b>104</b>
<b>WAND (MODEL W-02).....</b>	<b>104</b>
<b>TABLET WIRELESS.....</b>	<b>105</b>
<b>RNS<sup>®</sup> SYSTEM WIRELESS .....</b>	<b>105</b>
<b>ELECTROMAGNETIC EMISSIONS AND IMMUNITY.....</b>	<b>105</b>
Hospital or Medical Environments .....	106
Home, Work or Public Environments .....	106
Guidance and Manufacturer's Declaration .....	107
Emissions and Immunity Information .....	107
<b>GLOSSARY .....</b>	<b>112</b>
<b>INDEX .....</b>	<b>117</b>

## INTRODUCTION

### DEVICE DESCRIPTION

- **RNS® Tablet model 5000 with wand model W-02 and software version 1.9**
- **NeuroPace® Patient Data Management System model 4340**

### RNS® TABLET

The RNS® Tablet includes a tablet computer that runs proprietary NeuroPace software, and uses custom telemetry components to communicate with the RNS® Neurostimulator by holding the wand over it. The wand is applied to the patient (an applied part). Clinicians can use the tablet to program how the neurostimulator operates. Settings include, but are not limited to, the implanted system configuration, detection settings adapted to the patient's ECoG patterns, settings for ECoG record storage, and settings of the therapies. Clinicians can also use the tablet to review previously retrieved neurostimulator activity information, perform detection analysis, and communicate with the NeuroPace® Patient Data Management System (PDMS) via the Internet.

*Note: The term “programmer” as used in this manual is a generic term that refers to the RNS® Tablet.*

### NEUROPACE® PATIENT DATA MANAGEMENT SYSTEM

The Patient Data Management System (PDMS) maintains patient and product data obtained from the programmer and remote monitor. Authorized users may access the PDMS via the Internet using a personal computer. An electronic signature in the form of a username and password are required for user authentication.

### PRODUCTS AND ACCESSORIES

*Note: Manuals and other literature are not listed below.*

<b>RNS® Tablet Kit Model 5001</b>	
<b>Item</b>	<b>Model Number</b>
RNS® Tablet (with attached case)	5000
AC Adapter	
Carrying Bag	
<b>Used With</b>	
Wand	W-02

This manual contains information applicable to the RNS<sup>®</sup> Tablet, which is used to program how the RNS<sup>®</sup> Neurostimulator operates. It includes information about the secure Patient Data Management System (PDMS) database, which is accessible using the tablet or a web browser on a personal computer.

Refer to the RNS<sup>®</sup> System manual for additional device descriptions, device specifications, and indications for use, contraindications, warnings, cautions, and instructions for use.

All NeuroPace<sup>®</sup> manuals are available at [www.NeuroPace.com](http://www.NeuroPace.com) or by contacting NeuroPace, Inc. (see **Contacting NeuroPace** on page 5).

Refer to the clinical summary booklet for information on the clinical study results of the RNS<sup>®</sup> System and adverse event data.

## CONTACTING NEUROPACE

All questions or concerns regarding the NeuroPace<sup>®</sup> RNS<sup>®</sup> System should be forwarded to:

NeuroPace, Inc.  
455 N. Bernardo Ave.  
Mountain View, CA 94043

Customer Support: 866-726-3876 (Toll Free in the United States)

Website: [www.NeuroPace.com](http://www.NeuroPace.com)

## TYPOGRAPHIC CONVENTIONS

This manual uses the following typographic conventions.

### **WARNING:**    **WARNING TITLE**

Warnings alert you to serious adverse events and potential safety hazards and situations that may cause injury.

### **Caution:**    **Caution Title**

Cautions alert you to exercise special care.

*Note: Notes provide additional information.*

1. Numbered lists are used to identify a sequence of steps.

---

---

**This format is used to identify figure titles and descriptions**

---

---

**BOLD SMALL CAPS** indicate on-screen text, like the names of screens, buttons and fields.

*Note: Software version numbers found on screenshots in this manual are provided for illustrative purposes only and may not be the same as the version number you see on screen.*

**WARNINGS AND CAUTIONS – PROGRAMMER**

*Note: See the RNS® System manual for warnings and cautions regarding other components of the RNS® System.*

**WARNING: PHYSICIAN AND CENTER ACCESS TO THE RNS® SYSTEM**

The RNS® System should only be implanted by neurosurgeons with adequate experience in the implantation of subdural and stereotactic implantation of intraparenchymal electrodes and in the surgical treatment of intractable epilepsy. The RNS® System should only be used by neurologists or neurosurgeons with adequate experience in the management of intractable epilepsy and in the localization of epileptic foci, including the use of scalp and intracranial electrodes.

Neurologists and neurosurgeons using the RNS® System must have completed the NeuroPace® RNS® System training program. To qualify to manage patients with the RNS® System, physicians must demonstrate specific expertise related to epilepsy, video-EEG monitoring, interpretation of electrocorticograms (ECoGs), the pharmacology of antiepileptic medications and selection of patients for epilepsy surgery. Implantation of the RNS® System should be performed only by qualified neurosurgeons at centers capable of providing comprehensive epilepsy care, i.e. “Comprehensive Epilepsy Centers.” These centers should have the expertise to provide diagnostic services that include video-EEG monitoring with scalp and intracranial electrodes and neuroimaging, and are experts in the treatment of epilepsy with antiepileptic medications, epilepsy surgery, and devices.

**WARNING: MANAGEMENT OF PATIENTS WITH THE RNS® SYSTEM BY PHYSICIANS AT CENTERS THAT DO NOT PROVIDE THE SERVICES PROVIDED AT COMPREHENSIVE EPILEPSY CENTERS**

In some instances, post-implant programming may be conducted by neurologists meeting the experience and certification requirements for neurologists at Comprehensive Epilepsy Centers, but who are not practicing in such centers. This situation might occur if the patient is not able to travel to a Comprehensive Epilepsy Center for regular follow-up (e.g. because of distance from the Center or limited access to transportation). These neurologists will be qualified by NeuroPace to provide post-implant programming. After NeuroPace® RNS® System training is complete, the qualified programming neurologist may receive external NeuroPace products (programmer, remote monitor).

**WARNING: POTENTIAL SHOCK**

Submerging any part of the programmer, or operating the programmer in or near a wet environment, may result in an electrical shock.

The programmer must be disconnected from the electrical outlet prior to cleaning to avoid the potential of electrical shock.

Electrical shock may occur if the programmer AC adapter and power cord are not properly connected to a grounded power source.

Do not attempt to modify or repair the wand or programmer. Contact NeuroPace Customer Support for assistance.

**WARNING: RADIO FREQUENCY IDENTIFICATION (RFID) INTERFERENCE**

Sources of RFID can result in signals that appear as ECoG activity to the neurostimulator. Signals that appear as ECoG activity could also result in delivering the programmed stimulation to the patient (per the device detection programming). The physician should be aware of possible sensing artifacts when assessing the ECoG recordings. Potential sources of RFID may occur in a health care environment, retail stores, public libraries, airports and business environments.

Refer to ***Electromagnetic Emissions and Immunity*** on page **105** for more information.

**WARNING: SECURITY AND ELECTRONIC TRACKING SYSTEMS**

Security screening devices (such as theft detectors, security tag deactivators, and airport security screening devices) can result in signals that appear as ECoG activity to the neurostimulator. Signals that appear as ECoG activity could also result in delivering the programmed stimulation to the patient (per the device detection programming). Such devices may be found at retail stores, public libraries and airports. The physician should be aware of possible sensing artifacts when assessing the ECoG recordings. Patients should be instructed to walk through the center of such security screening units without stopping, when possible, and exit the area of the screening device as soon as possible.

**WARNING: NEUROPACE COMPONENTS**

Use of accessories, transducers, and cables other than those provided by NeuroPace could result in increased electromagnetic emissions or decreased electromagnetic immunity of the RNS<sup>®</sup> System and result in improper operation. Do not plug the wand into equipment other than the programmer because it could damage the wand. Do not use a USB cable extension from the programmer to the wand.

**WARNING: PORTABLE AND MOBILE RADIO FREQUENCY (RF) COMMUNICATIONS EQUIPMENT**

Portable and mobile RF communications equipment (including peripherals such as antenna cables and external antennas) should be used no closer than 12 inches (30 cm) to any part of the RNS<sup>®</sup> System, including cables. Otherwise, degradation of the performance of the RNS<sup>®</sup> System could result.

**WARNING: NEUROPACE<sup>®</sup> EQUIPMENT PLACEMENT**

Use of NeuroPace<sup>®</sup> equipment (for example, remote monitor or programmer) adjacent to or stacked with other equipment should be avoided because it could result in improper operation. If such use is necessary, the NeuroPace<sup>®</sup> equipment and other equipment should be observed to verify that they are operating normally.

**Caution: Telemetry Artifact**

Telemetry may produce an electrographic artifact. If responsive therapy is enabled with sensitive detection settings, detection of the electrographic artifact may occur resulting in therapy delivery. The physician should be aware of possible sensing artifacts when assessing the ECoG recordings.

**Caution: Afterdischarge Activity**

If evidence of afterdischarge activity resulting from stimulation is seen either on stored ECoGs or during test stimulation delivery, stimulation parameters should be adjusted to prevent such occurrence.

**Caution: Programmer Failure**

As with any electronic device, the programmer may be damaged or malfunction if the programmer AC adapter and power cord are not properly connected to a grounded power source.

**Caution: Incompatibility of Programmer with Other Medical Devices**

The effects of using the programmer to interrogate other electronic, programmable devices such as pacemakers, defibrillators, cochlear implants, and other neurostimulators or CPAP machines are unknown. It could result in reprogramming of the other device and therefore, the physicians familiar with each device should check the programmed parameters of each device before the patient is discharged and after each programming session of either device.

**Caution: Electronic Interference**

Communications between the programmer and the implanted neurostimulator may be interrupted by emissions from nearby electronic devices. Examples of sources of EMI are lithotripsy, computer monitors, cellular telephones, motorized wheel chairs, x-ray equipment and other monitoring equipment. Interruption of telemetry can result in incomplete communication. If EMI disrupts programming, move the programmer away from the likely source of EMI. Refer to **Poor or No Communication Between the RNS<sup>®</sup> Neurostimulator and the RNS<sup>®</sup> Tablet** (page 102) for more information.

**Caution: Placement of the Programmer Power Cord**

Make sure nothing rests on the programmer power cord and that the cord is not located where it can be tripped over or stepped on.

**Caution: Heating**

The programmer's AC adapter may become hot during normal operation. Use care when handling during or immediately after operation.

**STERILIZATION AND STORAGE****Product Storage**

Components should be stored in a clean and secure area with a room temperature of approximately 14 to 28 degrees Celsius.

**Explant and Disposal**

Program all detection and therapy functions to DISABLED prior to explanting and shipping the RNS<sup>®</sup> Neurostimulator. Return the explanted neurostimulator and leads to NeuroPace. NeuroPace will provide shipping containers if requested.

DO NOT incinerate the neurostimulator; explosion can occur if the neurostimulator is exposed to incineration or cremation temperatures.

---

**Return / Disposal of Programmer and Wand**

The programmer and wand should be returned to NeuroPace if you are no longer using them. They contain electrical parts that need to be disposed of in accordance with local regulations.

**Wand Maintenance, Cleaning and Sterilization**

The wand is not user-serviceable and requires no maintenance. The wand can be cleaned by wiping with water. It can be placed in a sterile bag for use in the sterile field. DO NOT STERILIZE the wand.

**Electrostatic Discharge (ESD) / Static Electricity**

The ports on the tablet may be sensitive to electrostatic discharge / static electricity. Handle the tablet ports carefully. If exposed to electrostatic discharge, the tablet may experience telemetry artifacts or errors, or may freeze. In the event of a tablet freeze, refer to **Tablet Freezes** on page **103**.

## RNS<sup>®</sup> TABLET INSTRUCTIONS

This chapter primarily addresses use of the tablet during an interactive programming session, that is, when the clinician uses the wand for communication between the neurostimulator and tablet. For information on using the PDMS apart from an interactive programming session, either using the tablet or using a web browser on a personal computer, see ***Patient List on Tablet and the PDMS on a Personal Computer*** on page 91.

### POWER ON THE TABLET

When interacting with a patient, the tablet should be used on battery power only. Make sure the tablet is sufficiently charged for use before powering on.

Press and hold the power button on the upper right side of the tablet. After 2-3 seconds, the tablet beeps to indicate it is powering on.

### CONNECT AND LOGIN OVERVIEW

Access to all of the functionality of the tablet requires an Internet connection and two logins, in this order:

1. **Connect to the Internet** via Wi-Fi or mobile broadband on the tablet. Mobile broadband works automatically. To connect to Wi-Fi, see ***Steps to Connect to a Wi-Fi Network*** on page 12. Alternatively, the tablet computer can also support use of a docking station that has an Ethernet connector (wired connection). Contact NeuroPace customer service if you prefer this alternative.
2. **Login to the tablet.** NeuroPace provides the initial username and password for this login.
3. **Login to the Patient Data Management System (PDMS)**, which requires the Internet connection established in the first step. NeuroPace also provides the initial username and password for the PDMS. (For PDMS access using a personal computer, select the PDMS link at [www.neuropace.com](http://www.neuropace.com) and log in. For further instructions, see ***PDMS Access on a Personal Computer*** on page 92.)

*Note: Programming functions that are typically performed in the operating room do not require an Internet connection to the PDMS.*

You can access all programming functions without connection to the PDMS (offline) except the following:

- View patient information stored on the PDMS, and (automatically) upload local patient data from the tablet to the PDMS, including ECoGs, neurostimulator activity and settings.
- Download custom programming sets from the PDMS for use offline. A programming set includes the settings for detection, stimulation, and ECoG capture.

For details, see ***Functionality with and without a PDMS Connection*** on page 11.

## FUNCTIONALITY WITH AND WITHOUT A PDMS CONNECTION

*Note: Programming functions that are typically performed in the operating room do not require an Internet connection to the PDMS. Default programming sets are always available on the tablet. However, when a patient's custom programming set will be programmed where there is no Internet connectivity, it is necessary to download the custom programming set from the Patient List to the tablet before use offline.*

The table below identifies the tablet functions that do not require an Internet connection to the PDMS and those that do.

Function	Internet Connection to the PDMS Required
Interrogate the neurostimulator	No
View neurostimulator information and settings downloaded during current session, including ECoGs, battery voltage, impedance, stimulation settings, recording montage	No
Create or change the recording montage	No
Set up or adjust ECoG capture settings	No
Select and program a default programming set or a custom programming set previously saved to the tablet from the PDMS. A programming set includes settings for detection, stimulation and ECoG capture.	No
Make a new programming set or adjust parameters of a programming set	No
View patient information stored on the PDMS, and (automatically) upload local patient data from the tablet to the PDMS, including ECoGs, neurostimulator activity and settings	Yes
Access programming sets stored on the PDMS, either to use immediately, or to download for later use offline	Yes

## CONNECT TO THE INTERNET FOR PDMS ACCESS

When connected to the Internet and logged in to the Patient Data Management System (PDMS), the RNS® Tablet provides a look-through to the information stored on the PDMS, such as ECoGs, neurostimulator settings and activity. The PDMS is a patient database integrated with the RNS® Tablet; the PDMS is also available using a browser on any Internet-connected computer. The tablet ships with Wi-Fi enabled, so it can detect available Wi-Fi networks out of the box.

*Note: If you attempt to connect to a Wi-Fi network that requires you to go to an Internet website to log in, as in some hotels and coffee shops, you will not be able to log in because the tablet does not have an Internet browser program. As a medical device, its Internet connectivity is restricted to the PDMS only.*

The tablet ships with Wi-Fi and mobile broadband enabled.

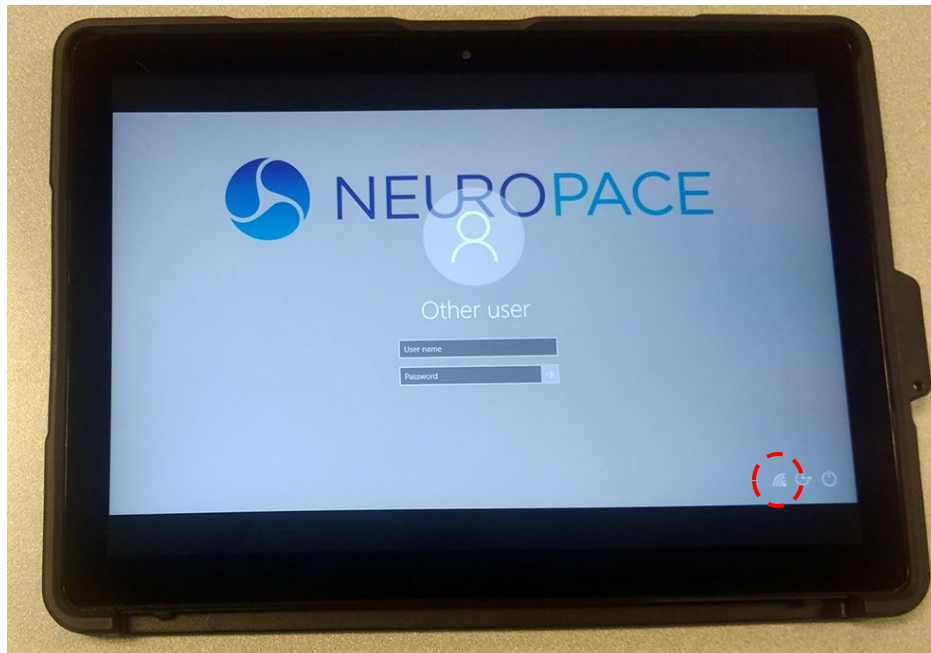
### **Mobile Broadband Works Automatically**

Mobile broadband is pre-configured by NeuroPace to be on and working, so no further effort is necessary and the tablet will connect to mobile broadband automatically if a signal is available.

### **Steps to Connect to a Wi-Fi Network**

Follow these steps to connect via Wi-Fi to the Internet on the RNS® Tablet.

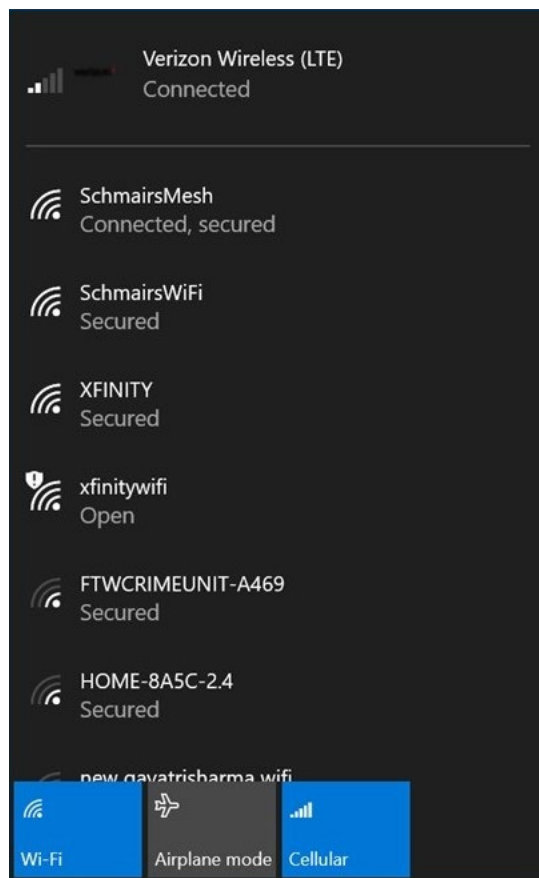
1. The tablet login screen appears first upon startup. Select a user. The screen prompts you for a username and password and displays the keyboard, but ignore these for now.
2. Touch to select the small symbol that indicates network status. (If necessary, touch outside the login fields to dismiss the keyboard and see the whole screen.)



**Figure 1 Touching the Wi-Fi network icon at lower right**



The Wi-Fi symbol with an asterisk above it indicates an available Wi-Fi network. Selecting the network status symbol opens the **NETWORKS** panel on the right side of the screen.



3. From this point, Wi-Fi access is the same as on a smartphone or laptop computer:
  - a. Select the desired network and then select **CONNECT**.
  - b. Enter the network security key and select **NEXT**. (The security key is your Wi-Fi password.) The tablet connects if the security key is correct. Internet connection is complete.

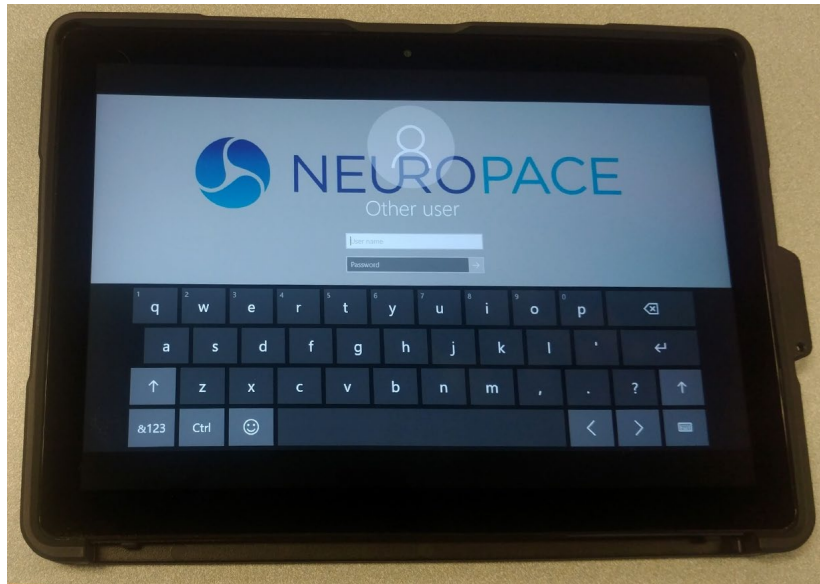
#### **If You Lose Network Connectivity**

If you lose network connectivity, you can wait for the signal to be restored or you can exit the tablet and try to connect to a Wi-Fi network. To do this, first log off to return to the tablet login screen: return to the Start screen and touch the circle-X (exit) button at upper right, and then select **EXIT** on the **PROGRAMMER EXIT** dialog. Then follow the **Steps to Connect to a Wi-Fi Network** on page 12. If you still cannot connect, contact NeuroPace for further assistance (see **Contacting NeuroPace** on page 5).

## LOG IN TO THE RNS® TABLET

This is the first of two logins. The second one gives you access to the PDMS.

1. The tablet login screen appears first upon startup. Select a user. The screen prompts you for a username and password and displays the keyboard.



2. Enter your username and password (initially provided by NeuroPace) and select **Enter**. Login completes if the password is correct. The tablet automatically checks for software updates.
  - a. If updates are available, the **NEUROPACE UPDATE CENTER** opens. Follow the instructions below to use the update center.
  - b. If there are no updates, the Start screen appears (see page 17), which lets you either interrogate a patient's neurostimulator to begin an interactive programming session, or select a patient from the Patient List, after logging in to the PDMS.

## NEUROPACE UPDATE CENTER

After logging into the tablet, the **NEUROPACE UPDATE CENTER** opens if any updates are available for installation. As described below, the Update Center identifies the update type(s) and allows you to select a convenient time to perform the updates.

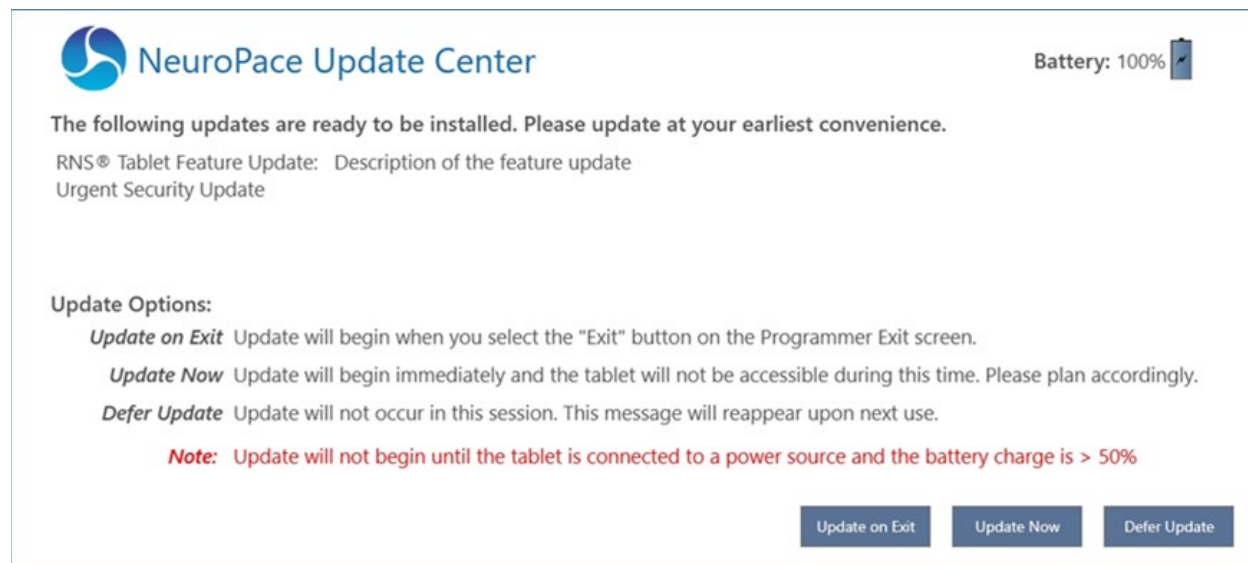


Figure 2 NeuroPace Update Center

### Update Types

1. **RNS Tablet Feature Update:** These updates contain tablet interface changes or new feature updates.
2. **Urgent Security Update:** These updates are required to ensure cybersecurity for the tablet and should be done as soon as possible. They do not include any tablet interface changes or new features.

*Note: Some updates require the tablet to restart. Under these circumstances, upon completion of the update, the system will restart automatically and will require you to log in again.*

### Update Options

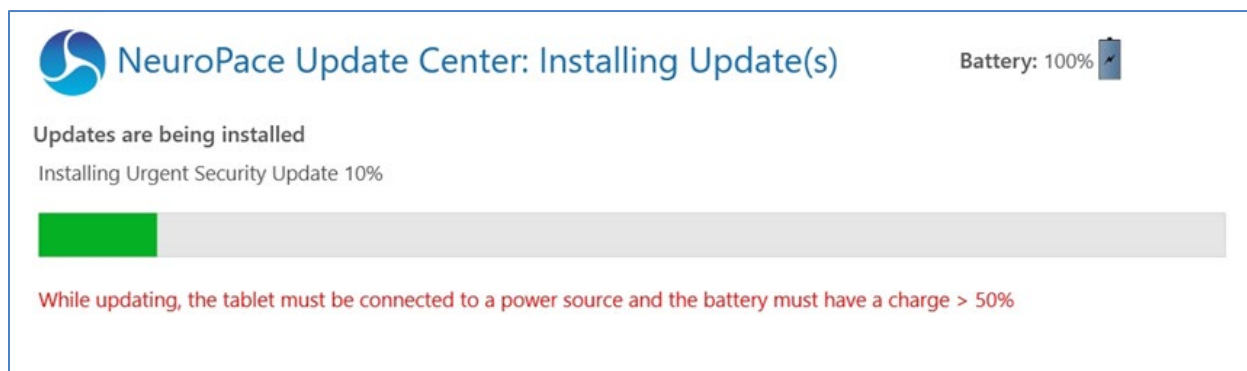
It is important to install updates, however the time it takes for an update to complete can vary from less than a minute to up to an hour. Accordingly, be sure to perform an update when you have enough time. Once an update starts it cannot be cancelled; interrupting an update by powering off the tablet can render the tablet unusable.

1. **UPDATE ON EXIT:** This option postpones the update until you select **Exit** on the **Programmer Exit** dialog. To maintain tablet availability within the next hour (i.e. for a patient clinic visit), we recommend selecting **UPDATE ON EXIT**.
2. **UPDATE NOW:** This option starts the update immediately and the tablet will not be available during this time. Do not use this option if the tablet is needed within the next hour.

3. **DEFER UPDATE:** This option postpones the update until the next use of the tablet, at which time the **NEUROPACE UPDATE CENTER** will appear again.

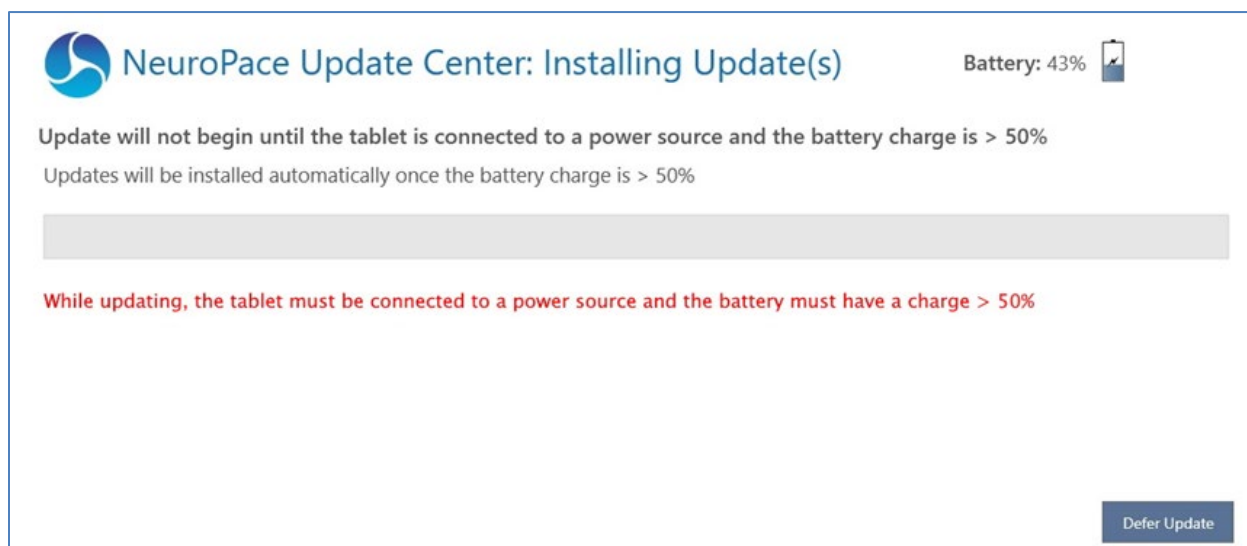
### **Update Process and Power Requirements**

When an update begins, the screen name shows **NEUROPACE UPDATE CENTER: INSTALLING UPDATE(S)** and reports update progress.



**Figure 3 Installing Updates Progress**

- **Power requirements:** Updates cannot proceed until tablet is connected to a power source and the battery charge is greater than 50%. These power requirements ensure that the tablet remains powered on throughout the update, so it is not interrupted. It is recommended to keep the tablet plugged in until the update completes.



**Figure 4 Power requirements must be met before updates will start**

If the power requirements are not met, instructions to address the unmet power requirements will be displayed and the progress status bar will not commence (see **Figure 4**). Follow the instructions on

screen as applicable to either plug in the tablet or wait for the battery to reach the required level. When the power requirements are met, the update will begin automatically.

If the power requirements have not been met and the update has not begun, you can select the option to **DEFER UPDATE** until the next time you log in to the tablet, at which time the **NEUROPACE UPDATE CENTER** will appear again.

## START SCREEN

The Start screen appears after tablet login.

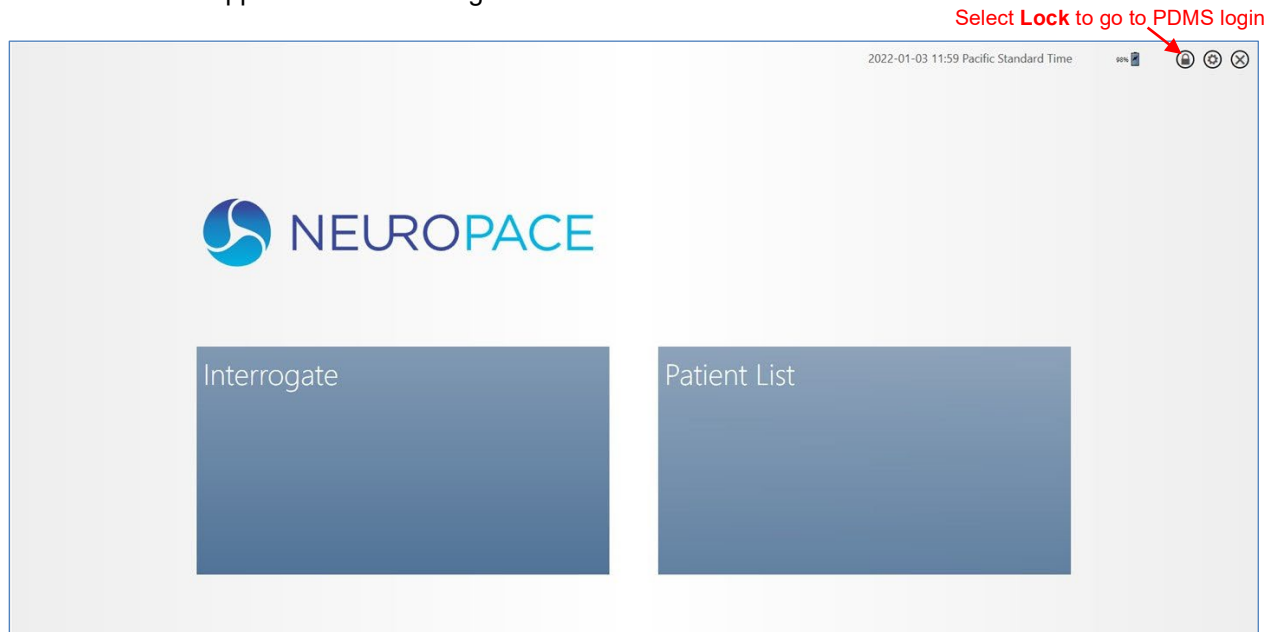


Figure 5 Start screen

**Interrogate:** Select the **Interrogate** tile to begin an interactive programming session with a patient present. Prior PDMS login is not required. For instructions to interrogate, see *Interrogate the RNS® Neurostimulator* on page 19.

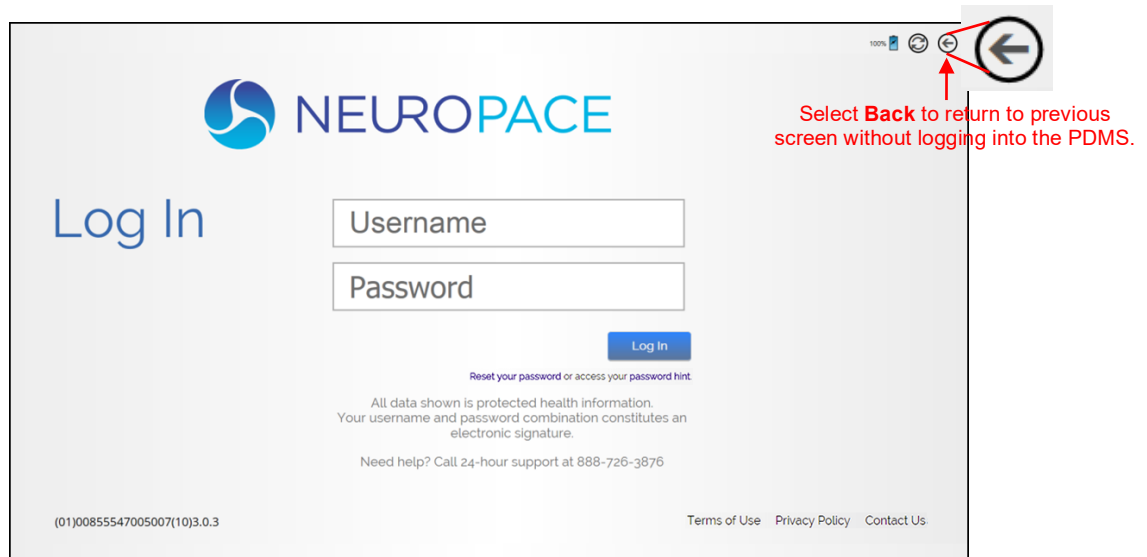
**Patient List:** Select the **Patient List** tile when you want to access patient information similar to the PDMS on a web browser. Selecting the **Patient List** tile takes you to the **PDMS Log In** screen (see *Figure 6*), where you are prompted to **Log In to the PDMS** (see page 18).

### Download a Programming Set for Offline Use

One important scenario to select the **Patient List** tile is when you plan to program a custom programming set in an operating room that lacks reliable Internet connectivity. The programming set must be downloaded directly from the PDMS to the tablet before surgery. For instructions in this scenario, see **Steps to Download a Programming Set to the Tablet for Offline Use** on page 74.

## LOG IN TO THE PDMS

The **NEUROPACE LOG IN** screen appears whenever you attempt to access functions that require PDMS access, like selecting the **PATIENT LIST**, **ECOG LIBRARY** or **ACTIVITY** tiles.



**Figure 6 PDMS Log In screen**

1. Select the fields to enter the username and password and then select **LOG IN**. Login completes and the screen advances.

## INTERROGATE THE RNS® NEUROSTIMULATOR

To interrogate the RNS® Neurostimulator means to identify it, perform routine tests and measurements, and retrieve currently programmed settings and stored data from it. Follow these steps to interrogate:

1. Connect the wand to the USB port on the tablet.

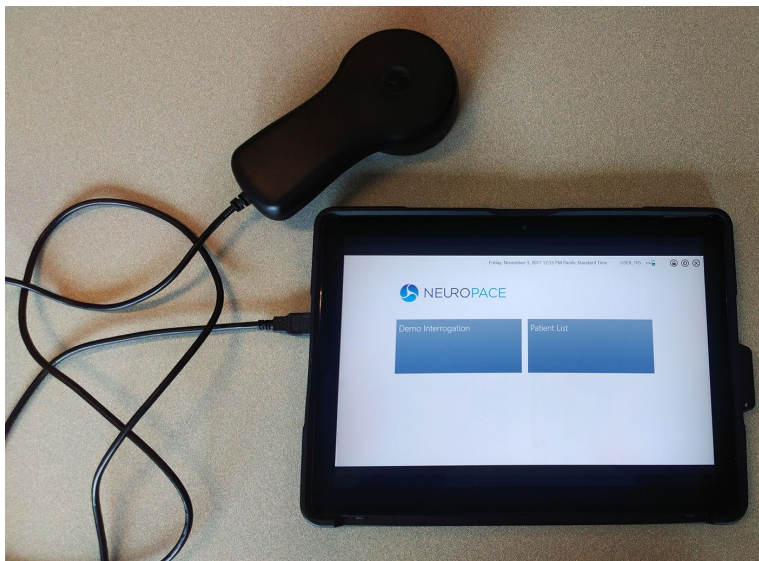


Figure 7 Tablet with connected wand

2. Place the wand within approximately 1 inch of the neurostimulator, concave side of wand facing the neurostimulator. Then select **INTERROGATE** from the Start screen (left tile—see **Figure 5**). You can also select the green **INTERROGATE** tile at upper right in the **HOME** screen (see **Figure 9**.) The wand must be held in place over the neurostimulator for interrogation to succeed.

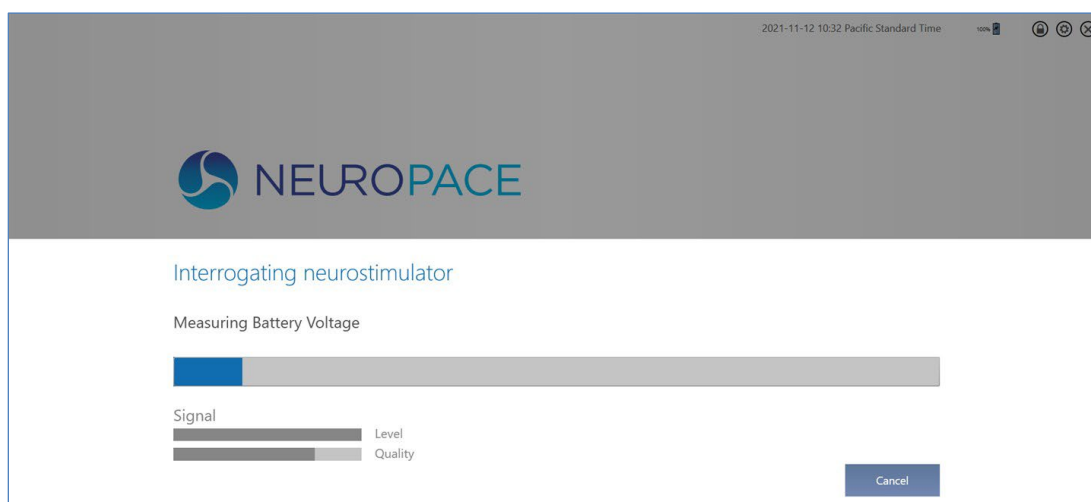


Figure 8 Interrogating neurostimulator dialog—interrogation in progress

The **INTERROGATING NEUROSTIMULATOR** dialog shows progress and the **HOME** screen appears when complete. It takes from 10 seconds up to 5 minutes, depending on the amount of data to be retrieved. Interrogation does not significantly drain the neurostimulator battery.

The dialog has bars that show the **LEVEL** and **QUALITY** of the **SIGNAL**. The **LEVEL** measures the strength of the communication between the neurostimulator and the tablet. The **QUALITY** measures the absence of electronic interference in the environment. Poor signal level or quality can result in **Poor or No Communication Between the RNS® Neurostimulator and the RNS® Tablet**—see page **102** for troubleshooting information.

## PROGRAMMING OVERVIEW: RECORDING MONTAGE AND PROGRAMMING SETS

### Recording Montage

The RNS® Neurostimulator can sense brain activity (ECoGs) from up to four amplifier channels. The programmed configuration of leads and electrodes you assign to each channel constitute the recording montage. You create the montage using the tablet. **Upon initial implant, you must create and program the recording montage to enable all other programming functions. There can be only one current montage and corresponding programming sets. When the montage is altered, the programming sets created with the previous montage become unavailable and a programming set corresponding with the new montage must be programmed.** (Note that if you change the montage to match a prior montage, the programming sets associated with the prior montage become available again.) Instructions for all programming activities follow in this manual, starting with **Create the Recording Montage** on page **38**.

### Programming Sets

A programming set includes the settings for detection, stimulation, and ECoG capture. You can change each kind of setting separately or in any combination, but all three kinds of settings are saved as part of a programming set. It is necessary after implant to first set up detection and ECoG capture to gather ECoGs with epileptiform patterns you can use to configure detection settings customized for the patient. Stimulation therapy is set up and enabled when you have established the patterns to detect and respond to with therapy. See the following sections for instructions to create or modify the elements of a programming set:

- **Set up ECoG Capture** on page **43**
- **Configure Detection: Define and Modify Detection Settings** on page **49**
- **Configure Responsive Therapy** on page **78**

### Preparing Programming Sets on the PDMS vs. within an Interactive Programming Session

Using the PDMS outside an interactive programming session, often via web browser, is the common and preferred way to prepare new programming sets for later programming in the clinic, before a patient's next visit. The common scenario is that clinicians create a new programming set on the PDMS after reviewing the patient's ECoGs and diagnostics stored on the PDMS, save the programming set with a new name (date and time are included after the name automatically), and share the new programming set with the users and programmers authorized to access the target patient's neurostimulator.

An interactive programming session using the tablet is the required means to change the programming of a patient's neurostimulator. An interactive session begins with interrogation of a

patient's neurostimulator using the wand connected to a tablet. A fundamental activity of an interactive programming session is to program the neurostimulator with a new programming set. During an interactive session, you can review and change all aspects of an available programming set before programming it, except you cannot select a specific ECoG pattern for detection or review simulated detection. A programming set created and programmed into the neurostimulator during an interactive programming session with a patient is automatically given the name "Clinic Set" with the date and time it is programmed.

Whether or not you actually program the neurostimulator, the interactive programming session persists on the tablet until you go back to the Start screen. Once outside of an interactive session, you can use the **PATIENT LIST** tile on the Start screen to login to the PDMS from the tablet. Apart from screen dimensions, the appearance and behavior on the available screens are the same as if you accessed the PDMS via a web browser. Exiting the patient list and interrogating a neurostimulator starts a new interactive programming session.

## DATA RETENTION AND ACCESS ON THE NEUROSTIMULATOR, PROGRAMMER AND PDMS

### Programmed Settings and Programming Sets

The neurostimulator retains its programmed settings until it is programmed again. These include the recording montage, ECoG capture triggers and reservations, and the detection and stimulation settings. A programming set includes settings for detection, stimulation and ECoG capture.

*Note: ECoG capture triggers are inactive during programming. **Programming clears activity information (diagnostics) and ECoGs stored in the neurostimulator.** If there is any new information, be sure to interrogate the neurostimulator prior to programming.*

### Storage of ECoGs and Neurostimulator Activity (Diagnostics)

**Between interrogations** by the patient or a clinician, the neurostimulator stores ECoGs and neurostimulator activity events up to its storage limit. (Neurostimulator activity events are also known as diagnostics, which include, for example, detection and stimulation events and magnet swipes.) Once the memory for ECoGs or diagnostics is full, the neurostimulator will store new data by overwriting the oldest ECoG or diagnostics. Reserved ECoGs are overwritten only by newer ECoGs of the same ECoG capture trigger type.

- The limit to the number of ECoGs stored on the neurostimulator depends on the capture duration you select in the ECoG capture settings (see **Set up ECoG Capture** on page 43 for details).
- You can make no adjustments that affect the number of neurostimulator activity events that can be stored. However, the number of events that can be stored is large compared to the number of ECoGs, because the data size of each event is relatively small.

**At each interrogation** with the remote monitor or programmer, the neurostimulator transfers all stored ECoGs and diagnostics to the programmer or remote monitor, at which point the successfully transferred data is cleared from the neurostimulator.

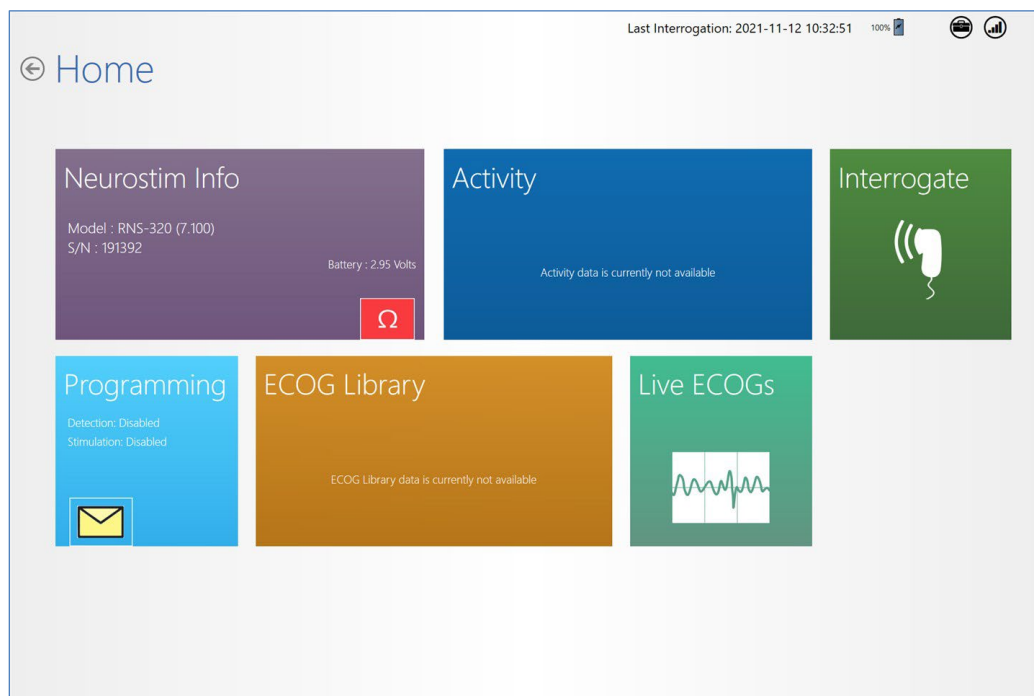
- If the programmer or remote monitor is not connected to the PDMS (via the Internet), the transferred data remains on the programmer or remote monitor hard drive. On the programmer, you can view ECoGs stored locally before PDMS upload, by selecting the **ECoG LIBRARY** tile.

- When the programmer is connected to the PDMS (via the Internet), the transferred data is automatically uploaded to the PDMS and cleared from the programmer memory. When the patient synchronizes using the remote monitor, data is transferred to the PDMS and cleared from the remote monitor. Data is retained on the PDMS.

*Note: If automatic upload to the PDMS does not complete successfully, data is not lost. Data is cleared from the programmer or remote monitor only after a successful upload.*

## HOME SCREEN

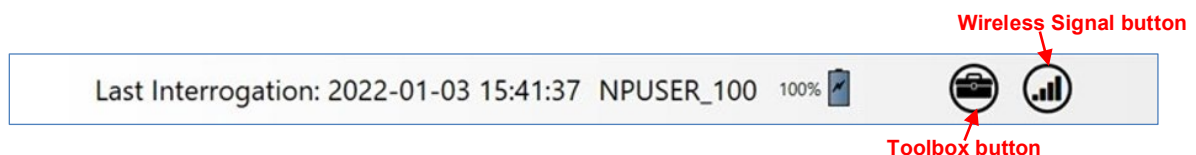
The Tablet **HOME** screen is the launch point for all programming activities.



**Figure 9** Tablet HOME screen

The elements in the far upper right of the screen are present on all tablet screens after interrogation.

- LAST INTERROGATION** date (YYYY-MM-DD) and time (24-hour time)
- Username (if logged in to the PDMS)
- Tablet battery status (%)



- **WIRELESS SIGNAL** button to access the **PDMS COMMUNICATION LOG**. Select **SYNC** to synchronize with the PDMS. Select **CANCEL** to close the log.

PDMS Communication Log

Time	Task	Status	Message	% Complete	Error Code
1/8/2016 12:35:05 PM	Background	DBMGR_SYNC	Synchronization completed successfully.	100	
1/8/2016 12:35:05 PM	Background	DBMGR_UPLOADING	Transferring Data...	66	
1/8/2016 12:35:05 PM	Background	DBMGR_UPLOADING	Transferring Data.	33	
1/8/2016 12:35:05 PM	Background	DBMGR_UPLOADING	Transferring Data.	0	
1/8/2016 12:35:05 PM	Background	DBMGR_UPLOADING	Transferring Data	0	
1/8/2016 12:35:05 PM	Background	DBMGR_UPLOADING	Transferring Data	0	
1/8/2016 12:35:05 PM	Background	DBMGR_UPLOADING	Connecting to PDMS.	100	
1/8/2016 12:35:05 PM	Background	DBMGR_UPLOADING	Connecting to PDMS.	0	

- **TOOLBOX** button to access **UTILITIES** dialog to **IMPORT DEVICE** and **EXPORT DEVICE SETTINGS**. These features are designed to support neurostimulator replacement. For instructions, see *Export and Import Device Settings for Neurostimulator Replacement* on page 88.



**Figure 10 Utilities dialog**

## NEUROSTIM INFO SCREEN

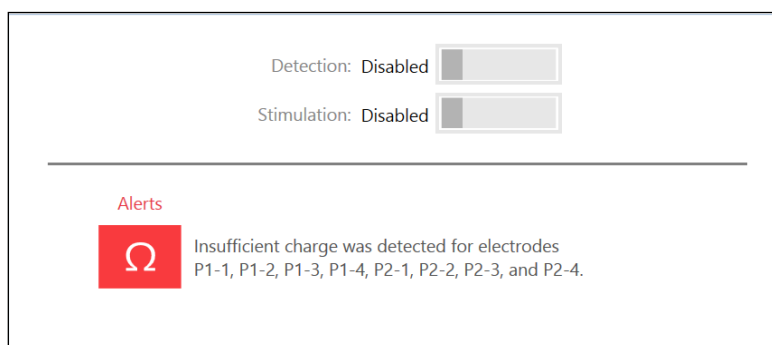
Select **NEUROSTIM INFO** from the **HOME** screen to open the **NEUROSTIM INFO** screen.



**Figure 11 Neurostim Info screen**

The **NEUROSTIM INFO** screen provides information about the neurostimulator, including:

- At upper left, whether **DETECTION** and **STIMULATION** are **ENABLED** or **DISABLED** and Alerts, if any

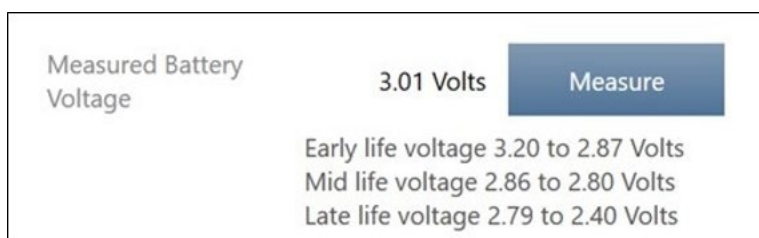


*Note: The alert for insufficient charge on all electrodes is characteristic of new implants until you **Create the Recording Montage** (see page 38) and measure impedance, as is normally done in the operating room.*

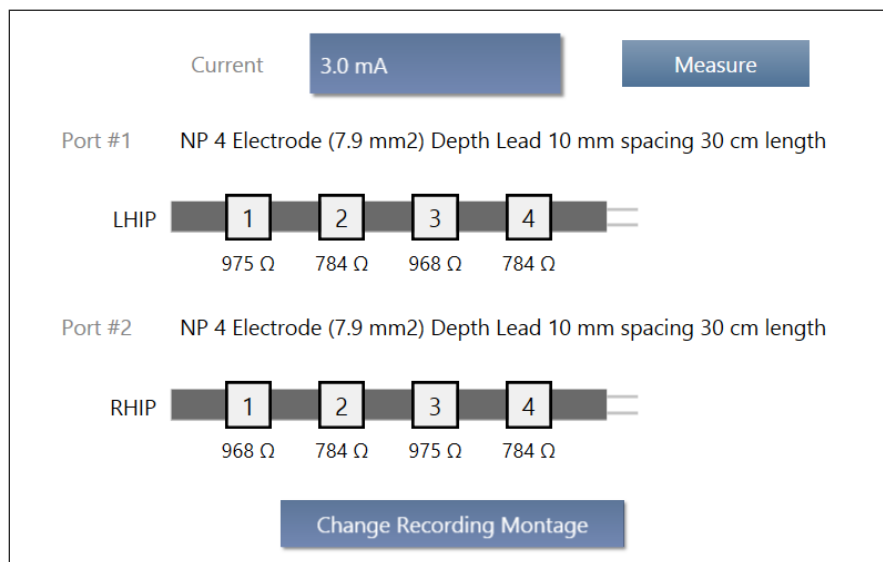
- At upper right, **MODEL**, serial number (**S/N**) and **LAST PROGRAMMED** date and time (24-hour time)



- At middle right, **MEASURED BATTERY VOLTAGE** with **MEASURE** button. The early, mid and late life voltage ranges are displayed to give context to the measured voltage. See **Significance of Battery Voltage** on page 28.



- At lower right, measured impedance for electrodes on the **PORT #1** and **PORT #2** leads



- Buttons to **MEASURE** impedance manually using the amount of **CURRENT** selected. (It is measured routinely during interrogation.)
- A button to **CHANGE RECORDING MONTAGE**, as explained under **Creating the Montage** on page 39

**MRI Mode for RNS Neurostimulator Model RNS-320**

*Note: MRI Mode software buttons and features are available only when you interrogate an RNS® Neurostimulator model RNS-320, which is MR Conditional. Refer to the MRI Guidelines for the RNS® System to determine patient eligibility for MRI and for the specific conditions required to safely perform an MRI scan on patients implanted with an RNS® Neurostimulator model RNS-320. Scanning under different conditions may result in device damage or malfunction and serious patient risks including permanent brain damage which may cause severe injury, coma, or death. All NeuroPace® manuals are available at [www.NeuroPace.com](http://www.NeuroPace.com) or by contacting NeuroPace, Inc.*



**RNS® Neurostimulator model RNS-300M** of the RNS® System is MR Unsafe. Having an MRI scan with a model RNS-300M neurostimulator implanted may result in serious injury or possible death.

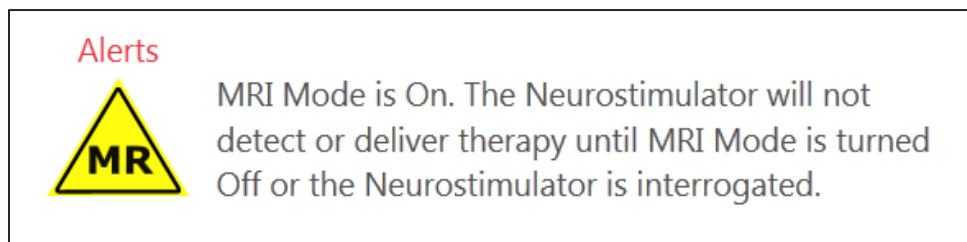
**RNS® System External Components:** All external components and accessories such as the Magnet, RNS® Tablet, NeuroPace® Programmer, NeuroPace® Remote Monitor, and Wand are MR Unsafe and can pose a projectile hazard in the MR environment, and therefore, must be kept out of the MRI scanner room.

Instructions to Turn MRI Mode ON

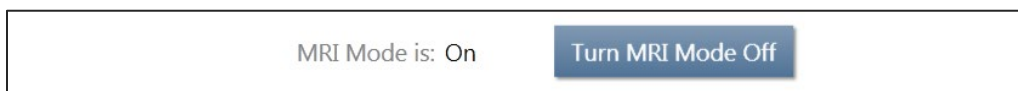
Using an RNS® Tablet, **MRI Mode** must be turned **On** prior to a patient implanted with an RNS® Neurostimulator model RNS-320 receiving an MR scan. This step must be completed outside the MRI scanner room, because the RNS® Tablet and Wand are MR Unsafe. Log in to the RNS® Tablet and interrogate the RNS® Neurostimulator. Select **Neurostim Info** from the **Home** screen to open the **Neurostim Info** screen. At bottom right, the **Neurostim Info** screen reports **MRI Mode is: Off** and provides the corresponding button to **Turn MRI Mode On**.



To turn MRI Mode on, place the wand within approximately 1 inch of the neurostimulator, concave side of wand facing the neurostimulator, and select **Turn MRI Mode On**. The tablet immediately sends the programming signal to turn MRI Mode on. A telemetry dialog indicates progress. Upon completion, the **Neurostim Info** screen displays an alert at upper left indicating that MRI Mode is on.



At bottom right, the screen reports **MRI Mode is: On**, and the button toggles to **Turn MRI Mode Off**.



*Note: It is strongly recommended that the neurostimulator remain in MRI Mode only for as long as necessary. While in MRI Mode, the neurostimulator is not detecting or delivering therapy to the patient. Additionally, the neurostimulator uses more battery power in MRI Mode than in normal operating mode. Note that the neurostimulator can be in MRI Mode for up to approximately two days per year without affecting battery longevity. Battery longevity estimates are specified in the RNS<sup>®</sup> System Physician Manual.*

*Note: Device status, including MRI Mode status, will propagate to the Patient Data Management System (PDMS) whenever the RNS<sup>®</sup> Tablet is connected to the internet, and therefore become available to all authorized users.*

### Instructions to Turn MRI Mode OFF

Using an RNS<sup>®</sup> Tablet, **MRI MODE** must be turned **OFF** after a patient implanted with an RNS<sup>®</sup> Neurostimulator model RNS-320 receives an MR scan. This step must be completed outside the MRI scanner room, because the RNS<sup>®</sup> Tablet and Wand are MR Unsafe.

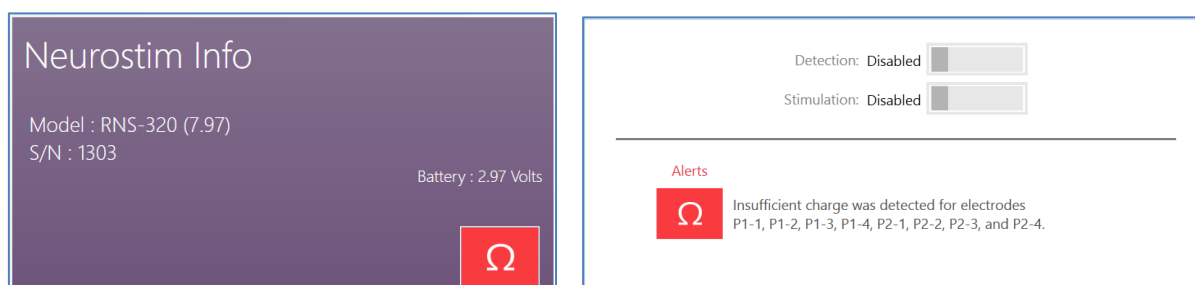
*Note: Please verify that the MRI scan was performed or cancelled prior to turning off MRI Mode.*

**Method 1:** If the **NEUROSTIM INFO** screen remains open on the RNS<sup>®</sup> Tablet that was used to turn MRI Mode on, the button at bottom right of the **NEUROSTIM INFO** screen can be used to turn MRI Mode off. Select **TURN MRI MODE OFF** (while holding the concave side of the wand within approximately 1 inch of the neurostimulator) to turn MRI Mode off. This scenario may occur, for example, if a clinician with an RNS<sup>®</sup> Tablet is present immediately before the MR scan to turn MRI Mode on, and afterward to turn MRI Mode off.

**Method 2:** Interrogation of the RNS<sup>®</sup> Neurostimulator with any RNS<sup>®</sup> Tablet turns off MRI Mode. During interrogation of a neurostimulator with MRI Mode on, a notification on the RNS<sup>®</sup> Tablet says that continuing the interrogation will turn MRI Mode off. Select **CONTINUE** to proceed with interrogation and turn MRI Mode off.

### Electrode Impedance and Battery Voltage

Interrogation includes measuring electrode impedance and battery voltage, and these measurements are reported on the **NEUROSTIM INFO** screen. The **NEUROSTIM INFO** tile and screen show an alert if the impedance measurement detects insufficient charge for one or more electrodes.



**Figure 12** Insufficient charge alert shown on the **NEUROSTIM INFO** tile and screen

To measure these items again, place the wand within approximately 1 inch of the neurostimulator and select the applicable **MEASURE** button on that screen (select **NEUROSTIM INFO** from the **HOME** screen to

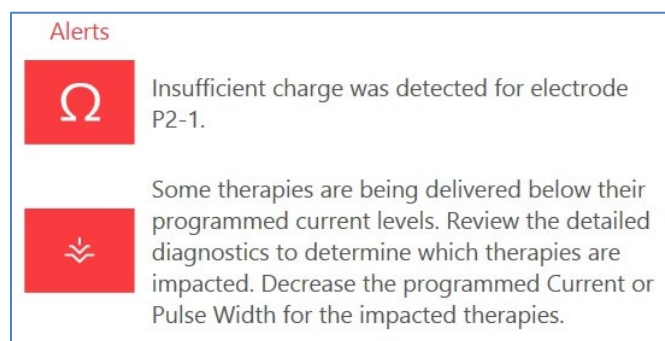
get there). For impedance measurements, use the **CURRENT** field to adjust the current delivered during measurement.

*Note: The system cannot measure impedance during a detected episode or during therapy delivery. To measure impedance, either wait for the episode or therapy to complete, or disable detection and therapy.*

#### Significance of Impedance

Impedance measurements are useful for verifying the integrity of a particular electrode. Each impedance measurement delivers a single pulse of current between an electrode and the neurostimulator canister (can) to measure the voltage that results as the current flows. Impedance measurements are reported in Ohms (voltage divided by current).

Impedance measurements greater than 3500 Ohms or less than 250 Ohms are considered abnormal. If impedance measurements are abnormally high, there may be insufficient charge to deliver therapy. When this is the case, alerts may appear on the Neurostim Info screen as shown in **Figure 13**.



---

**Figure 13 Alerts when there is insufficient charge to deliver therapies**

---

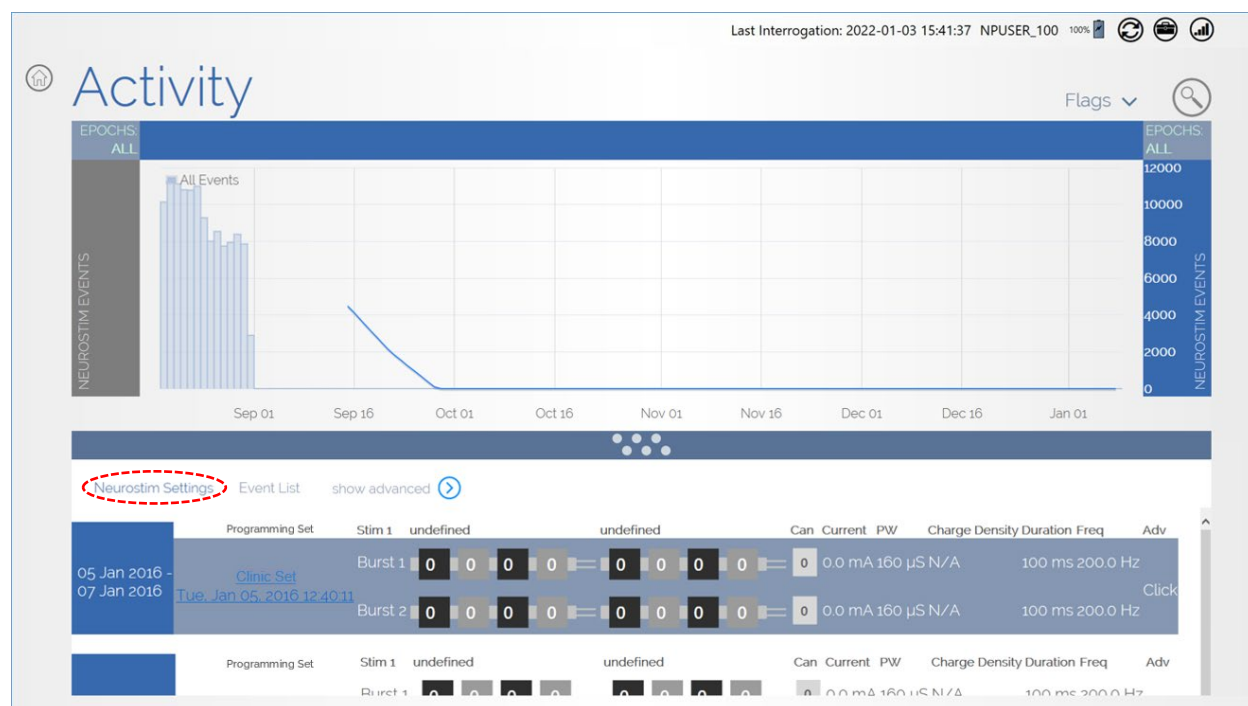
For troubleshooting information, refer to **Abnormal Lead Impedance (greater than 3500 Ohms or less than 250 Ohms)** on page **98**; and **Insufficient Charge** on page **101**.

#### Significance of Battery Voltage

The tablet displays current battery voltage and the early, middle, and late life battery voltage ranges to provide an understanding of remaining neurostimulator battery life. The elective replacement indicator (ERI) appears approximately three months before the neurostimulator reaches end of service (EOS). For example, for the RNS® Neurostimulator model RNS-320, normal battery voltage measurements are between 2.41 and 3.20 Volts. When the battery voltage measurement drops to 2.40 Volts or less, neurostimulator replacement is recommended, and the tablet notifies you on screen by showing the elective replacement indicator (ERI).

## ACTIVITY SCREEN

Select **ACTIVITY** from the **HOME** screen to open the **ACTIVITY** screen.



**Figure 14 Activity screen**

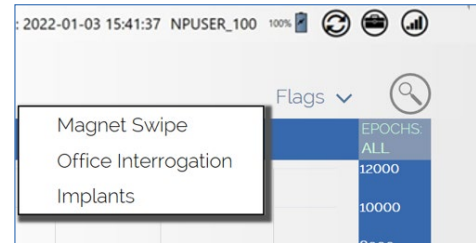
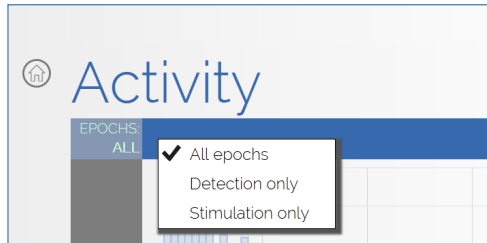
*Note: You must be logged in to the PDMS to access the **ACTIVITY** screen. If you are not, the **NEUROPACE LOG IN** screen opens when you select **ACTIVITY**, prompting you to log in. (See **Log In to the PDMS** on page 18.) If you are not connected to the Internet, see **Connect to the Internet for PDMS Access** on page 11.*

The upper part of the **ACTIVITY** screen is a histogram that shows the number of detection and stimulation events over time. Swipe left or right over the dates to view earlier or later activity. The lower part of the screen shows (by default) a list of the **NEUROSTIM SETTINGS**—detection and stimulation settings—used over time, one row for each period of time between programming changes, which is called a programming epoch. More view options are described below.

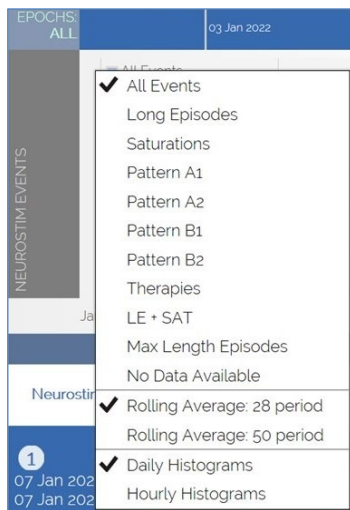
**Activity Histogram Viewing Options**

The interface provides many options for viewing activity.

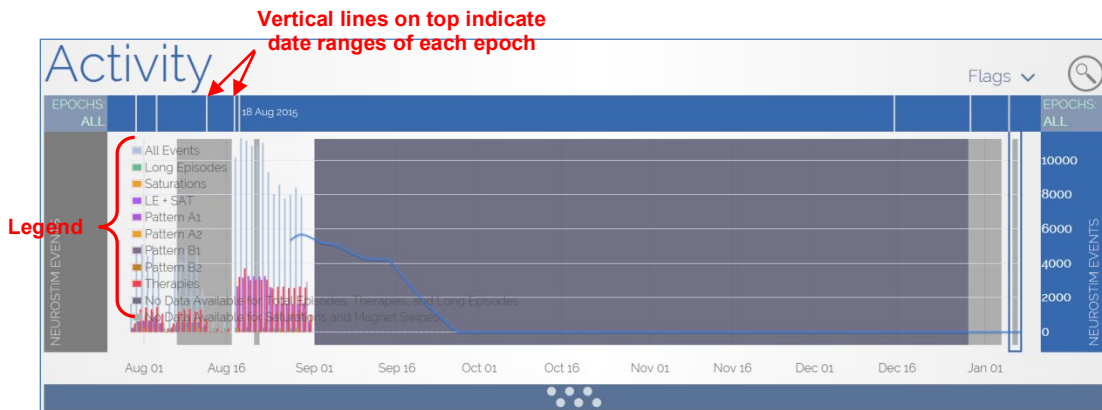
- Select **EPOCHS** at upper left or right to see events from **ALL EPOCHS**, **DETECTION ONLY** or **STIMULATION ONLY**.
- Select **FLAGS** at upper right to see events flagged with **MAGNET SWIPE**, **OFFICE INTERROGATION** or **IMPLANTS**.



- Select **NEUROSTIM EVENTS** on the left or right sides of the histogram to select items for layering on the graph; you can select multiple items concurrently, up to all items in the upper part of the list. A color legend appears on the left to help you recognize what is on the histogram.



Select event types to layer on graph



**Figure 15 Activity histogram with all events showing and supporting legend on left**

### View Neurostim Settings

The lower part of the **ACTIVITY** screen details the history of detection and stimulation settings used—collectively called **NEUROSTIM SETTINGS**—between each iteration of programming (each programming epoch), which are in rows from most recent on top to oldest on the bottom. Drag up the gray separator bar to view more of these settings, which will cover the upper histogram portion. Swipe up on the setting rows to view more rows, if they are present.

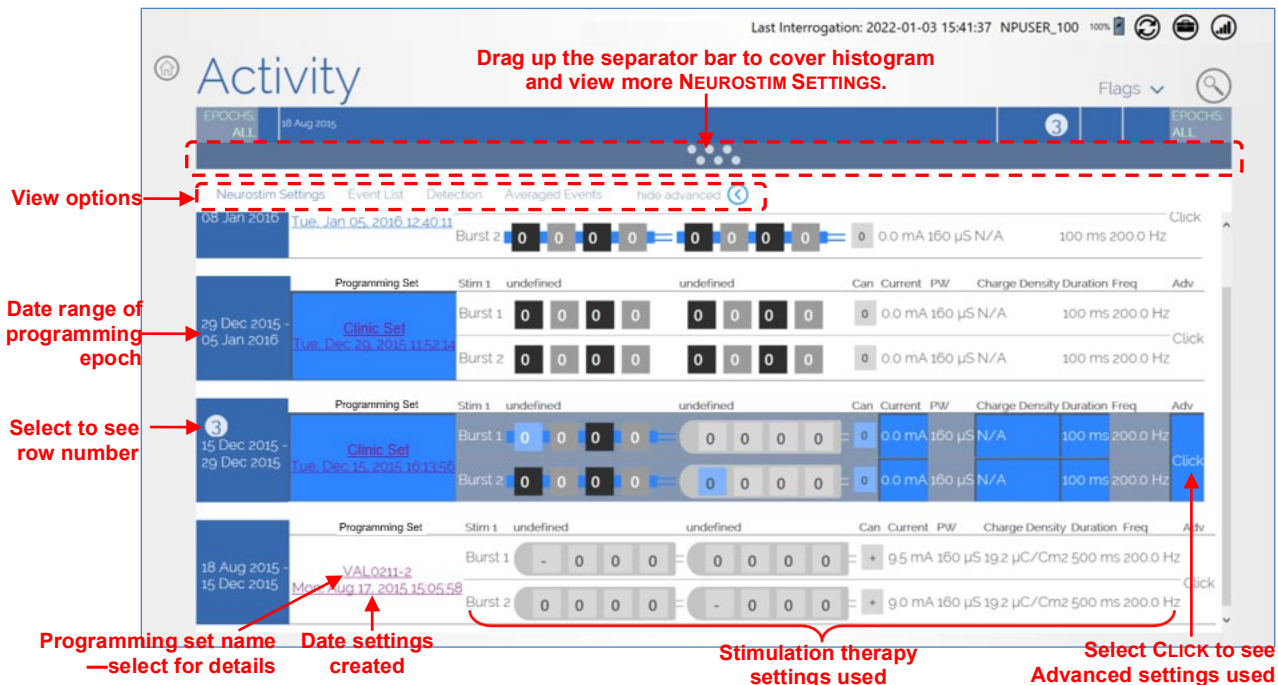
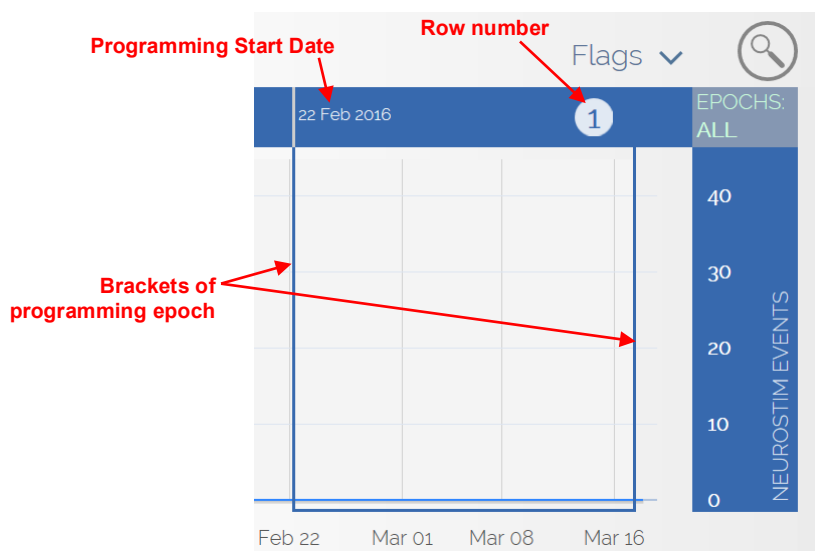


Figure 16 Activity screen—view detection and stimulation settings used between programming sessions

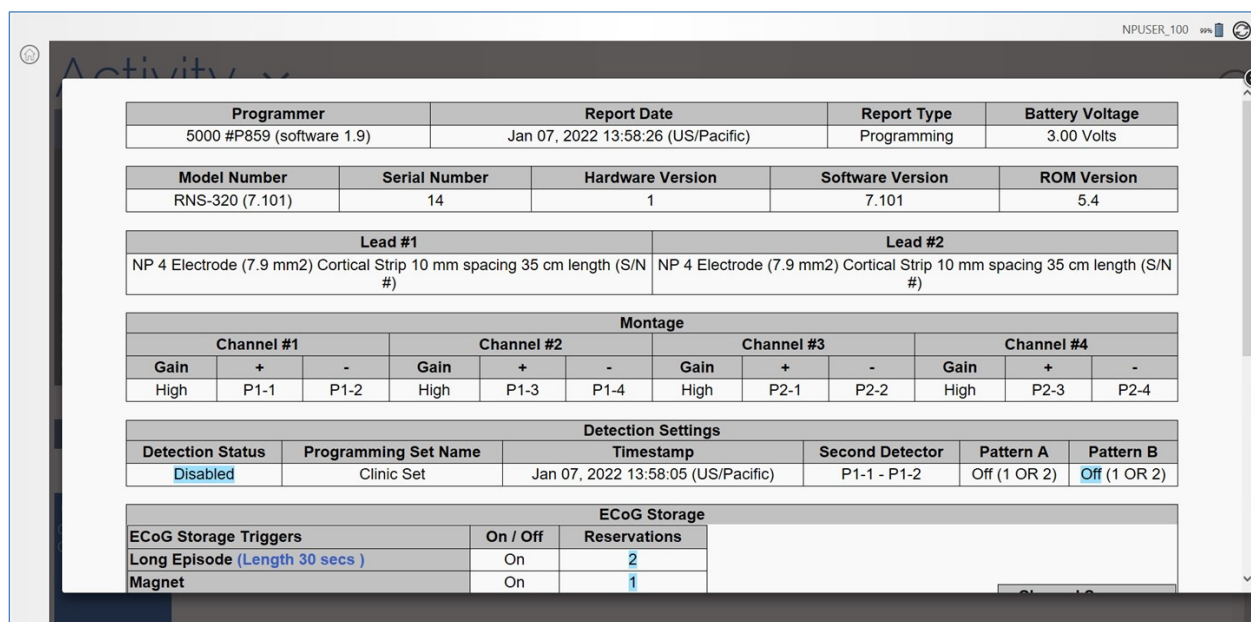
At the left end of each row is a blue tile showing the date range when those **NEUROSTIM SETTINGS** were used. Vertical lines above the histogram correspond to these dates (see **Figure 15** above). When you select a blue tile, its row number appears on the tile (see **Figure 16** above, row numbers increase as you go down).

Also the corresponding time period is bracketed in the histogram graph, and the row number and start date appear over the bracketed time period, if there is enough room on screen (see **Figure 17**). This helps to relate the programming changes to the device activity.



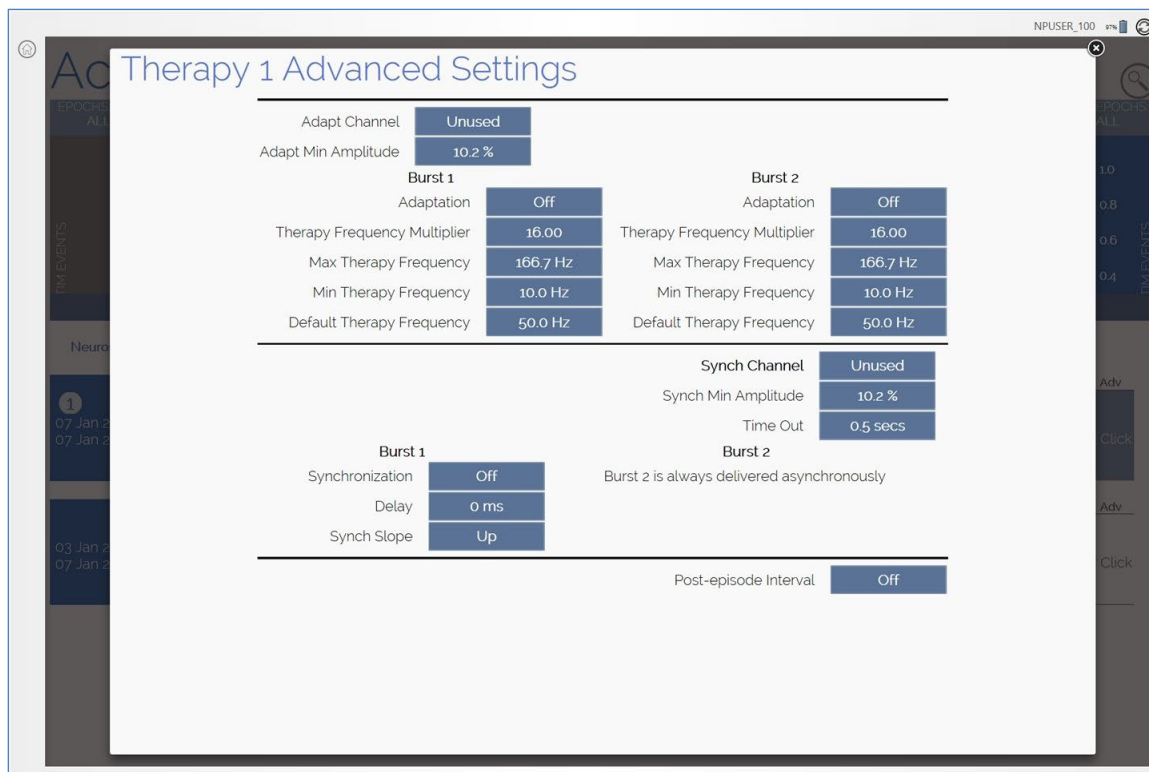
**Figure 17** Activity histogram excerpt showing programming epoch 1 bracketed

Next to the blue tiles, the second column in **Figure 16** shows the name of the **PROGRAMMING SET**. Select the name to view its details in the screen that opens (**Figure 18**). Touch the circle-X (exit) button at upper right to close.



**Figure 18** Programming set details

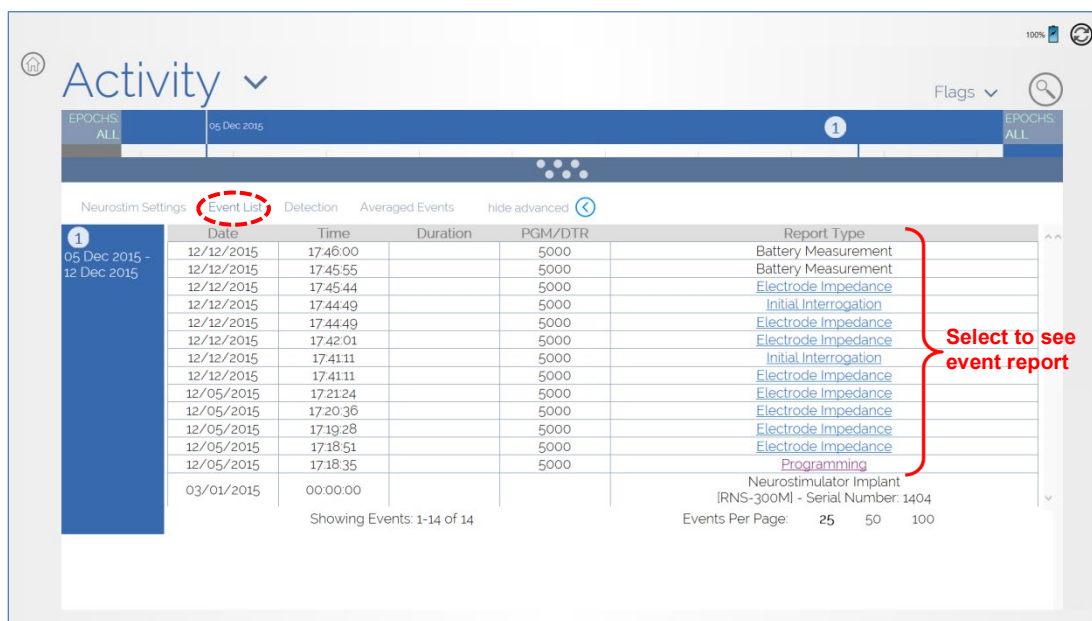
At the right end of each row in **Figure 16** is the **Adv** (Advanced) column. Touch **CLICK** below **Adv** to view the advanced stimulation therapy settings used in that programming epoch in the **THERAPY 1 ADVANCED SETTINGS** screen (**Figure 19**). Touch the circle-X (exit) button at upper right to close.



**Figure 19 View Advanced Stimulation Therapy Settings**

### View Event List

Select **EVENT LIST** next to **NEUROSTIM SETTINGS** above the left end of the row (**Figure 20**) to see a complete list of events for all rows. From there, select links under **REPORT TYPES** for detailed reports on each event. Scroll or swipe up or down to see the event list and to scroll between programming epochs.



**Figure 20 Event List selected—lists all events in a Neurostim Settings period, with links to reports**

### Types of Reports

There are six types of patient reports:

- **Interrogation** (Initial or Subsequent within the tablet session) ▶ Interrogation time/date
  - Programmed Neurostimulator settings
  - Event counters (# of detections, stimulations, etc.)
  - Event date/time and details
- **Programming**
  - Programming date/time
  - Programmed Neurostimulator settings
- **Electrode Impedance**
  - Impedance measurement date/time
  - Impedance measurement of each electrode (in ohms)
- **Battery Measurement**
  - Battery measurement date/time
  - Battery measurement value (in volts)

- **Therapy Testing** (shows therapy testing values)
- **ECoG**
  - ECoG trigger time/date
  - ECoG record
  - ECoG trigger reason
  - ECoG markers (detections, stimulations, etc.)

### Advanced Views

**DETECTION**, **AVERAGED EVENTS** and **PROGRAMMING EPOCHS** are the advanced views. **DETECTION** shows a graph of detection occurrence percentage for each programmed detection pattern since the last change in detection settings. **AVERAGED EVENTS** shows a week by hour histogram of the normalized average number of detected episodes per hour for the last 12 weeks. **PROGRAMMING EPOCHS** shows the history of recent programming epochs, summarizes the settings and activity of each epoch, and highlights the changes in settings and activity from one epoch to the next.

## ECoG LIBRARY SCREEN

It is recommended to review ECoGs stored in the library to assess how early and how often detections occur and the electrographic response to stimulation therapies delivered. Select **ECoG LIBRARY** from the **HOME** screen to open the **ECoG LIBRARY** screen, which displays thumbnails of all ECoGs stored for the current patient.

*Note: You must be connected to the PDMS to access the ECoG library. If you are not, the **NEUROPACE LOG IN** screen opens when you select **ECoG LIBRARY**, prompting you to log in. (See **Log In to the PDMS** on page 18.) If you are not connected to the Internet, see **Connect to the Internet for PDMS Access** on page 11.*

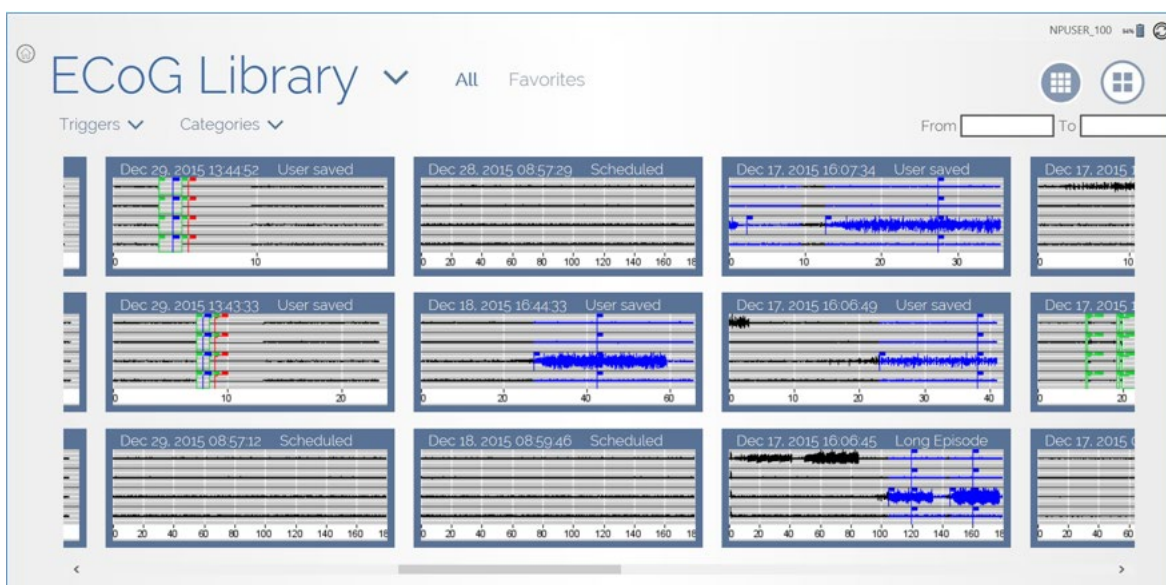
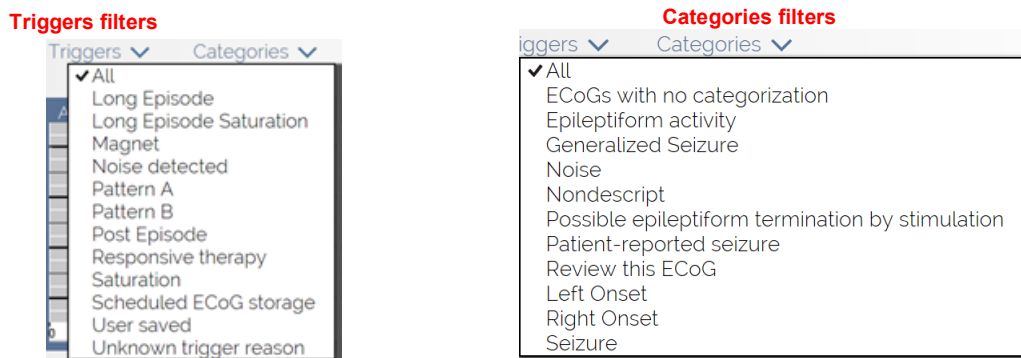


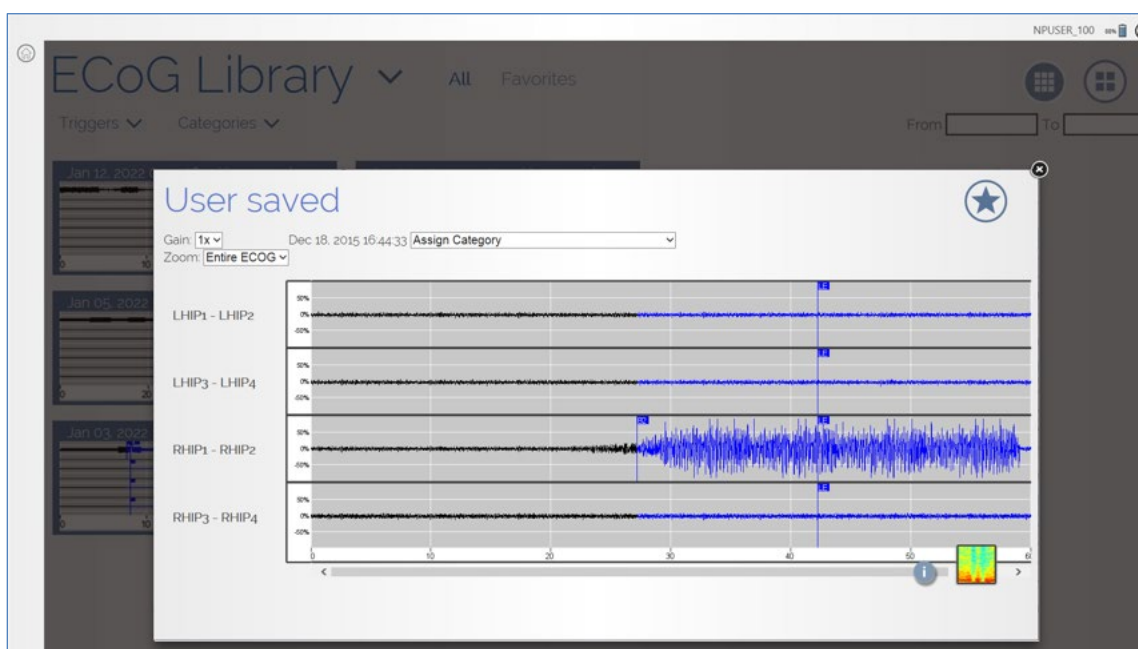
Figure 21 ECoG Library screen

Each ECoG is identified by date and time captured and by capture trigger. Newest ECoGs are on the left, older ones toward the right. Swipe left or right to view all ECoGs. You can filter which ECoGs are displayed using **TRIGGERS** and **CATEGORIES** at upper left (**Figure 21**). Use the **FROM** and **TO** fields at upper right to view ECoGs by date range.



**Figure 22** Filter stored ECoGs by triggers and categories

At top center (see **Figure 21**), you can select **ALL** or **FAVORITES** to display ECoGs by those classifications. Select a thumbnail to open it in a larger size, as shown below.



**Figure 23** Viewing a User saved ECoG

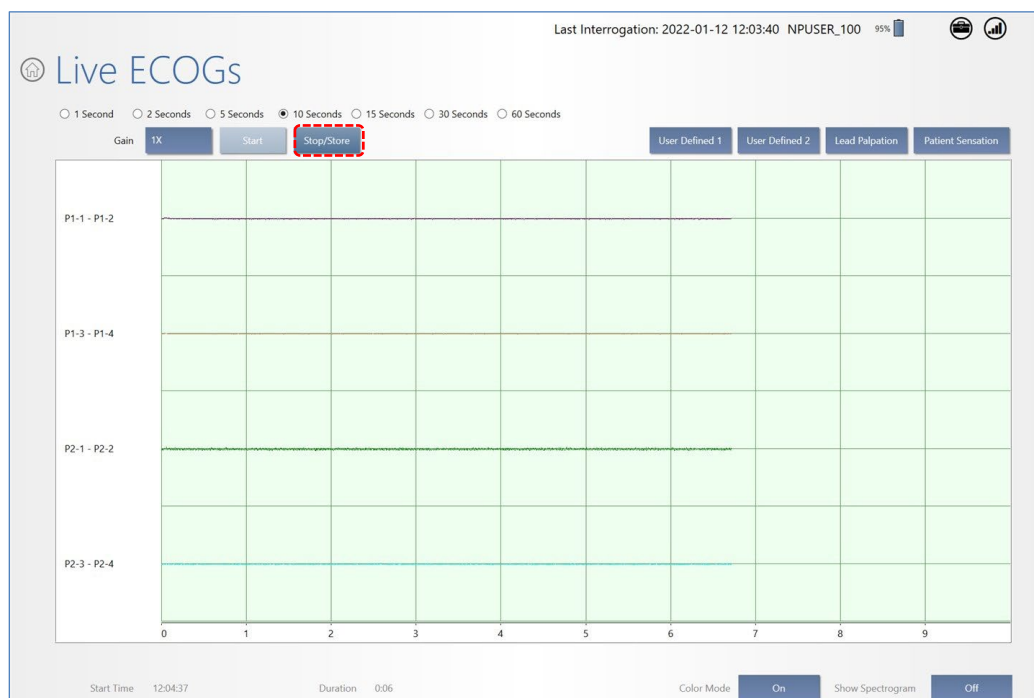
ECoGs highlight detection and stimulation events. Detected activity appears in blue. Undetected activity appears in black. Colored flags mark specific points of detection or stimulation. You can **ZOOM** in on the ECoG and increase the **GAIN**. Use the **ASSIGN CATEGORY** field to assign the ECoG to a category. Select the **STAR** button at upper right to specify this ECoG as a favorite, for fast access later using the **FAVORITES** filter on the **ECoG LIBRARY** screen.

Captured ECoGs reside in the RNS® Neurostimulator memory until they are transferred to the programmer or the remote monitor, at the next interrogation with the wand, and are then cleared from memory. If neurostimulator memory capacity is reached, captured ECoGs are overwritten by subsequent ECoGs. The number of ECoGs that can be stored depends on the duration of each ECoG, which you can specify in the **CAPTURE WINDOW** field in the **DURATION** area on the far upper right side of the **ECoG CAPTURE** screen. See **Selecting ECoG Capture Settings** on page 43 for details.

## LIVE ECoGs SCREEN

*Note: You can access the **LIVE ECoGs** screen only after interrogation of the neurostimulator, and the wand must be held within approximately 1 inch of the neurostimulator to acquire live ECoGs.*

After interrogation, keep the wand in place and select **LIVE ECoGs** from the **HOME** screen to open the **LIVE ECoGs** screen. An ECoG is live when you open it. Buttons provide various options for viewing the live ECoG. Select **STOP/STORE** to save the ECoG in the patient's ECoG library. It remains on screen after you stop and store it until you start another live ECoG. Captured live ECoGs are stored in the **ECoG LIBRARY** and classified as *User saved*.



**Figure 24 Live ECoGs screen**

Live ECoG capture can be useful for immediate or later analysis of patient ECoGs, for adjusting amplifier gain settings, and for simulated detection as part of **Configure Detection: Define and Modify Detection Settings** (see page 49).

*Important Note: The recording montage must be programmed before live ECoGs can be viewed. See **Create the Recording Montage** on page 38.*

*Note: The maximum length for a live ECoG is four minutes. If the live ECoG is allowed to scroll for more than four minutes, only the last four minutes are stored.*

*Note: Live ECoGs are stored on the tablet, not in the neurostimulator memory, and are uploaded to the PDMS if and when the tablet is connected to the PDMS.*

**Caution: Telemetry Artifact**

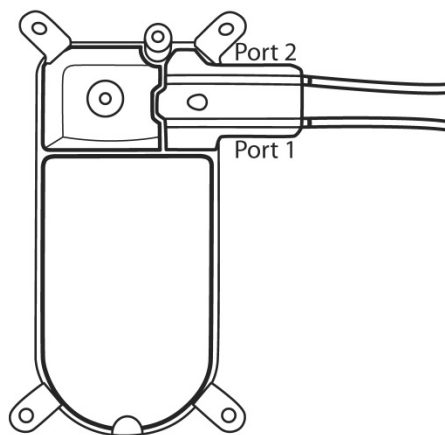
Telemetry may produce an electrographic artifact. If responsive therapy is enabled with sensitive detection settings, detection of the electrographic artifact may occur, resulting in therapy delivery. The physician should be aware of possible sensing artifacts when assessing the ECoG recordings.

## CREATE THE RECORDING MONTAGE

The RNS<sup>®</sup> Neurostimulator can sense brain activity (ECoGs) from up to four amplifier channels. The programmed configuration of leads and electrodes you assign to each channel constitute the recording montage. You create the montage using the tablet. **Upon initial implant, you must create and program the recording montage to enable all other programming functions. There can be only one current montage and corresponding programming sets. When the montage is altered, the programming sets created with the previous montage become unavailable and a programming set corresponding with the new montage must be programmed.** (Note that if you change the montage to match a prior montage, the programming sets associated with the prior montage become available again.)

### Identifying Ports, Leads and Electrodes on the Neurostimulator

The figure below identifies neurostimulator **PORT #1** and **PORT #2** with their leads extending out of the ports.



---

**Figure 25 RNS<sup>®</sup> Neurostimulator port #1 and #2 locations. Port #1 is closer to the center of the neurostimulator and port #2 is closer to the edge.**

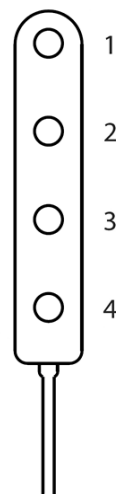
---

For both depth leads and cortical strip leads, the electrodes are numbered 1 through 4 starting from the distal end of the lead.

Distal End of Depth Lead

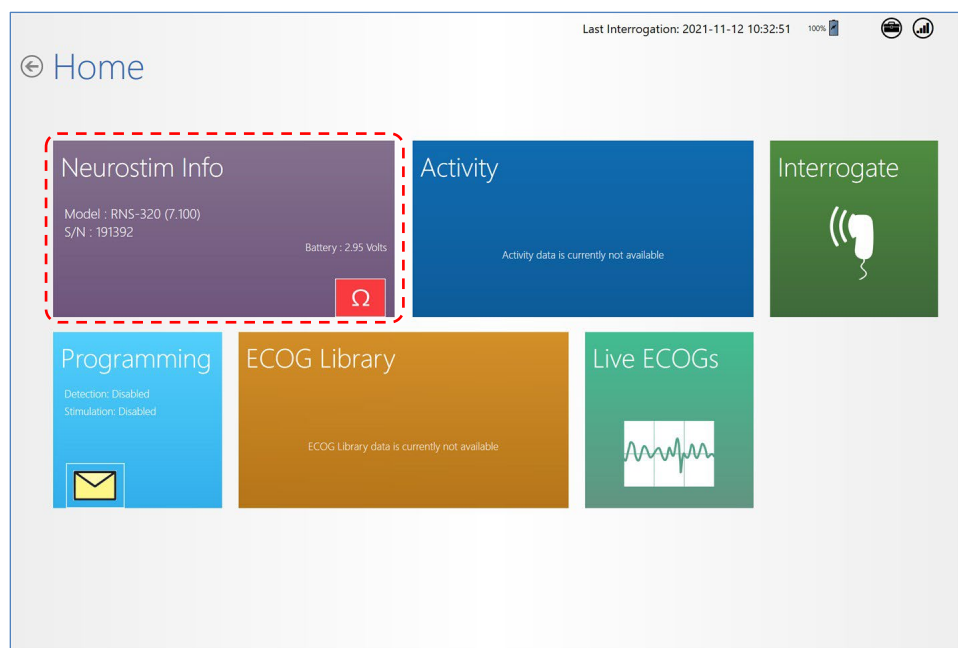


Distal End of Cortical Strip Lead



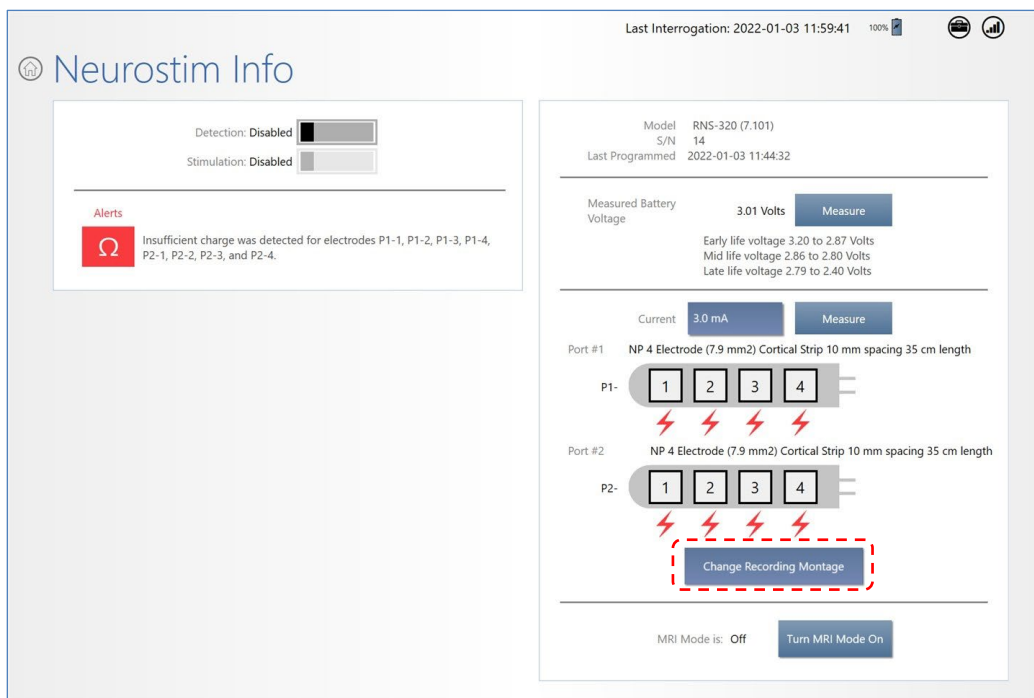
**Figure 26** For both lead types, electrodes are numbered 1 through 4. Electrode 1 is most distal.

### Creating the Montage

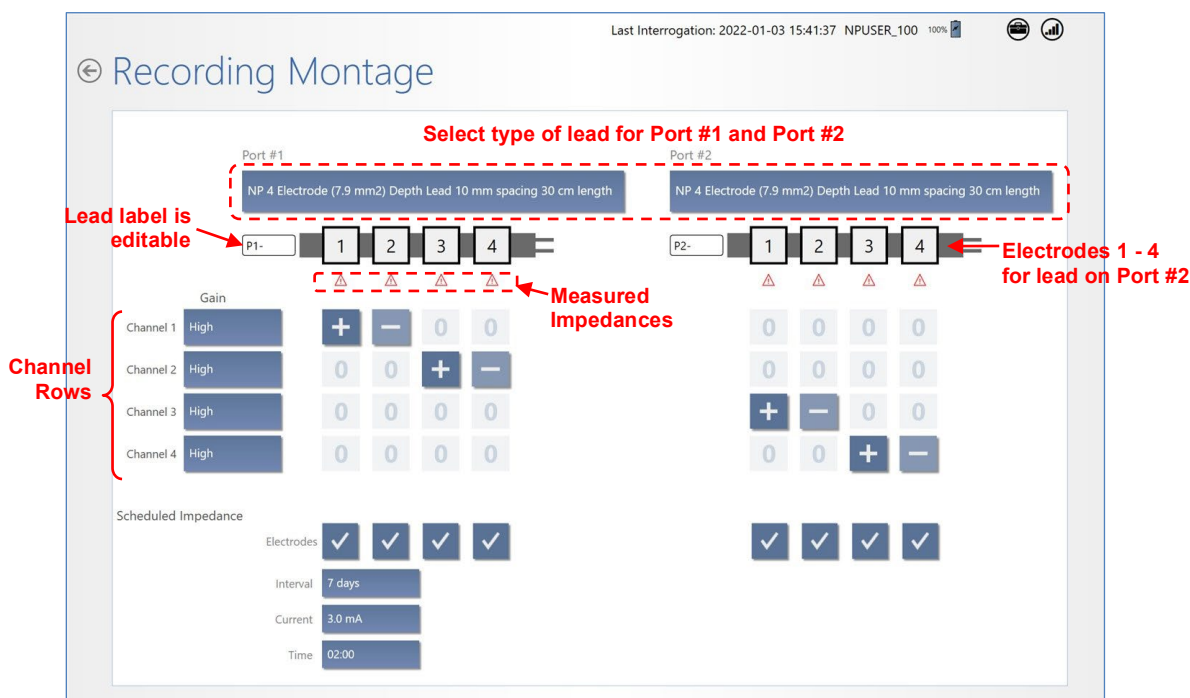


1. From the **HOME** screen, select **NEUROSTIM INFO**. The **NEUROSTIM INFO** screen opens.

*Note: Changed settings are highlighted blue and new setting text is shown in larger font above the smaller previous setting. Gray or plain items have not changed.*



2. On the **NEUROSTIM INFO** screen, select **CHANGE RECORDING MONTAGE** at lower right. The **RECORDING MONTAGE** screen opens.



**Figure 27 Recording Montage screen**

3. **At Neurostimulator Implant and When Changing Leads – Select Lead Type:** Upon first use of leads, you must select the lead type for **PORT #1** and/or **PORT #2**. To do this, select the

field that says **NONE**, just below the **PORT #1** or **PORT #2** names at the top, and select the type of lead installed in each port. When lead types are already selected for the ports, proceed to the next step.

4. **Assign Channels:** Use the channel rows and electrode columns to assign two electrodes to each **CHANNEL** (1 through 4). To do this, select the small, square field where the channel and electrode intersect and then select a positive [+] non-inverting input, a negative [-] inverting input, or zero [0]. Sensing occurs across the selected electrodes for each channel.

Each electrode can be assigned to one or two channels, and any electrode assigned to 2 channels must have the same input (+ or -). Use a positive (+) input for an electrode assigned to 2 channels.

*Note: Using a negative (-) input for electrodes assigned to 2 channels is not advisable as it may result in post-stimulation ECoG artifacts.*

5. **Set Gain:** Next to the channel name on the left, select the **GAIN** field for each channel to select **HIGH**, **MEDIUM-HIGH**, **MEDIUM-LOW**, or **LOW**. The default is **HIGH** and it is usually not changed. After programming, you can assess ECoG signal amplification by viewing the live ECoGs.
6. **Scheduled Impedance Settings:** These settings are at lower left. By default, the tablet schedules an impedance test on all electrodes every 7 days with 3.0 mA current at 2:00 AM. Select the fields next to **INTERVAL**, **CURRENT** and **TIME** to choose different settings. Normally there is no need to use other than the default settings.

#### **Recommended Initial Montage Settings**

- **Channel 1** = Lead 1: Electrode 1 [+], Electrode 2 [-]
- **Channel 2** = Lead 1: Electrode 3 [+], Electrode 4 [-]
- **Channel 3** = Lead 2: Electrode 1 [+], Electrode 2 [-]
- **Channel 4** = Lead 2: Electrode 3 [+], Electrode 4 [-]
- **GAIN** set to **HIGH** for all channels (default)
- **SCHEDULED IMPEDANCE** settings = Interval: 7 days, Current: 3.0 mA, Time: 2:00 AM (defaults)

#### **Program the Neurostimulator with the New Settings**

The new settings are not sent to the neurostimulator until you complete this step.

7. Select **REVIEW ALL CHANGES** at upper right (**Figure 28**). All **PENDING PROGRAMMING CHANGES** appear on the **PROGRAMMING SETS** screen (**Figure 29**) for your review before programming. Scroll down if necessary to see all the changes.

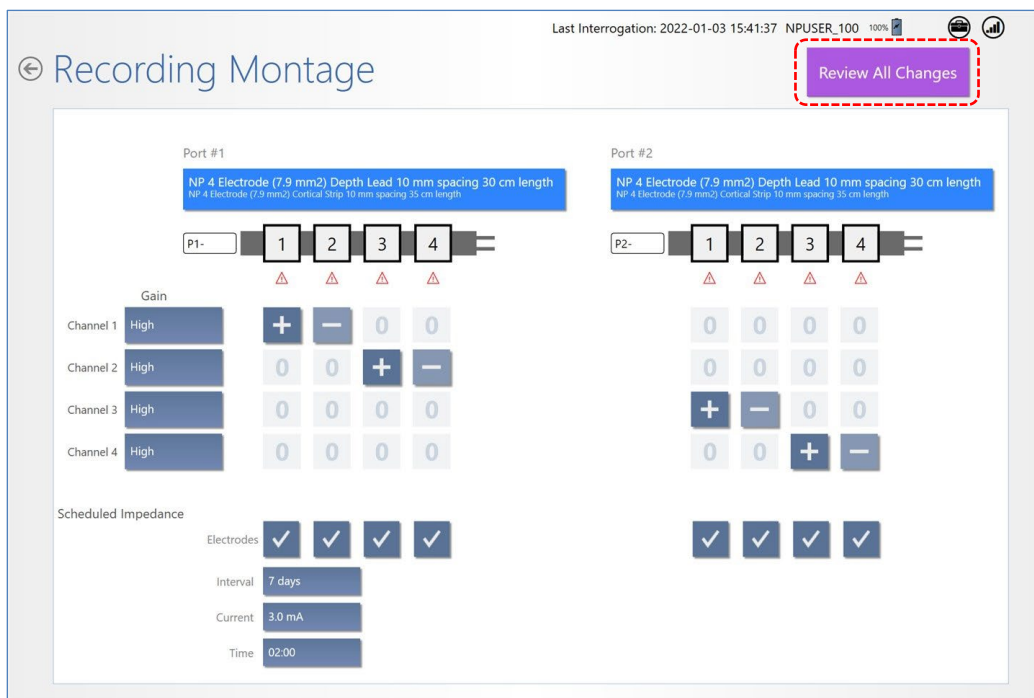


Figure 28 Recommended initial montage settings

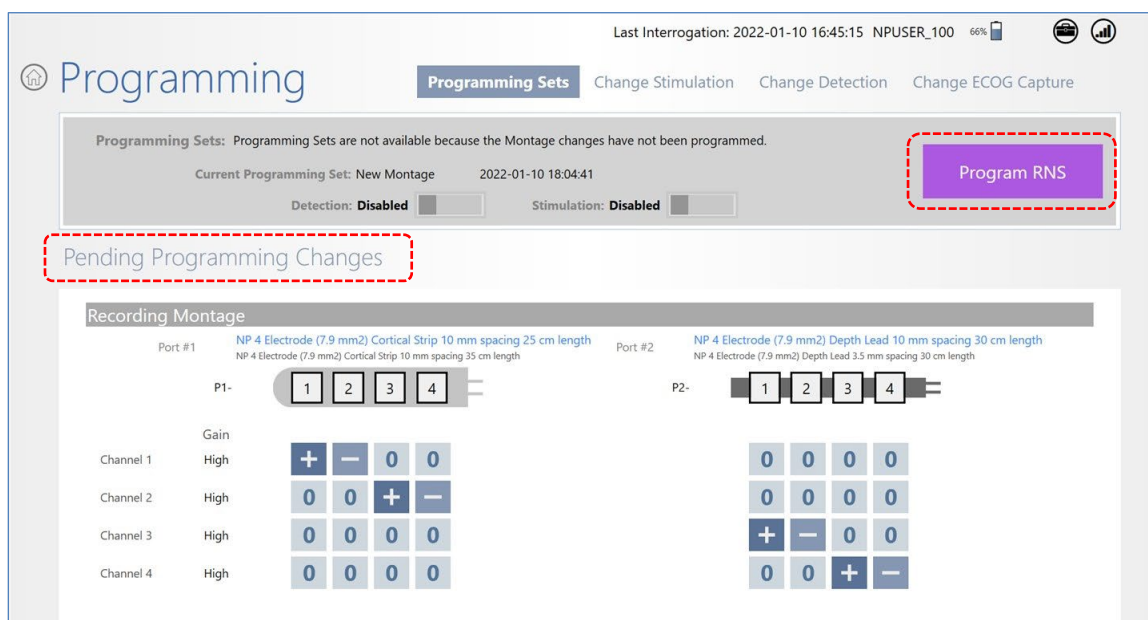
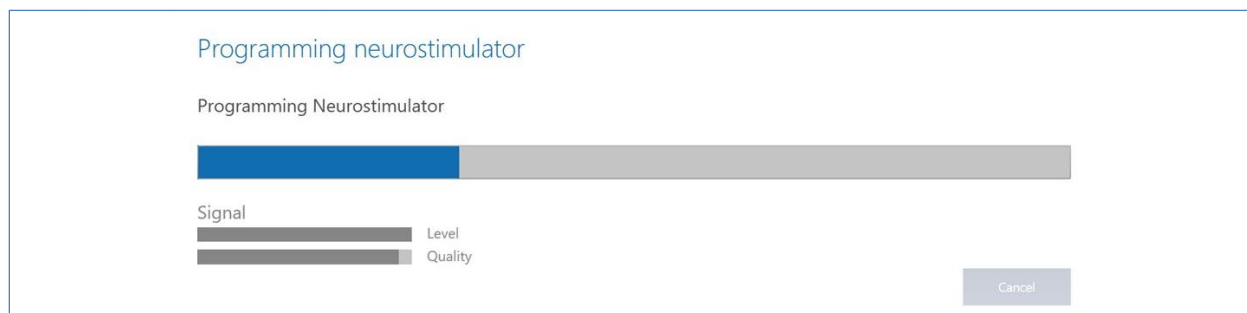


Figure 29 Pending Programming Changes for montage

8. If you are satisfied with the new or changed settings, place the wand within approximately 1 inch of the neurostimulator and select **PROGRAM RNS**. The Programming Neurostimulator dialog shows programming progress.



**Figure 30 Programming neurostimulator dialog shows progress of programming**

When complete, you return to the **PROGRAMMING SETS** screen. The programming set will be named **NEW MONTAGE** with date and time of its creation. You have created the recording montage, which is the prerequisite to create settings for detection, stimulation, and ECoG capture.

## SET UP ECoG CAPTURE

Electrocorticograms (ECoGs) can be stored by the RNS® Neurostimulator when an ECoG capture trigger occurs. The maximum number of ECoGs that can be stored is affected by the number of channel(s) selected ON for storage, and the pre-trigger and post-trigger durations. The oldest stored ECoGs are continually replaced by the newly stored ECoGs, except as noted below.

The number of ECoGs stored for a particular ECoG capture trigger can be reserved. Reserved ECoGs are only overwritten by newer ECoGs of the same ECoG capture trigger type.

ECoG capture may also be scheduled at four different times on a 24-hour clock.

### Selecting ECoG Capture Settings



1. Select **PROGRAMMING** from the **HOME** screen.

2. On the **PROGRAMMING** screen, select **CHANGE ECoG CAPTURE** at upper right.

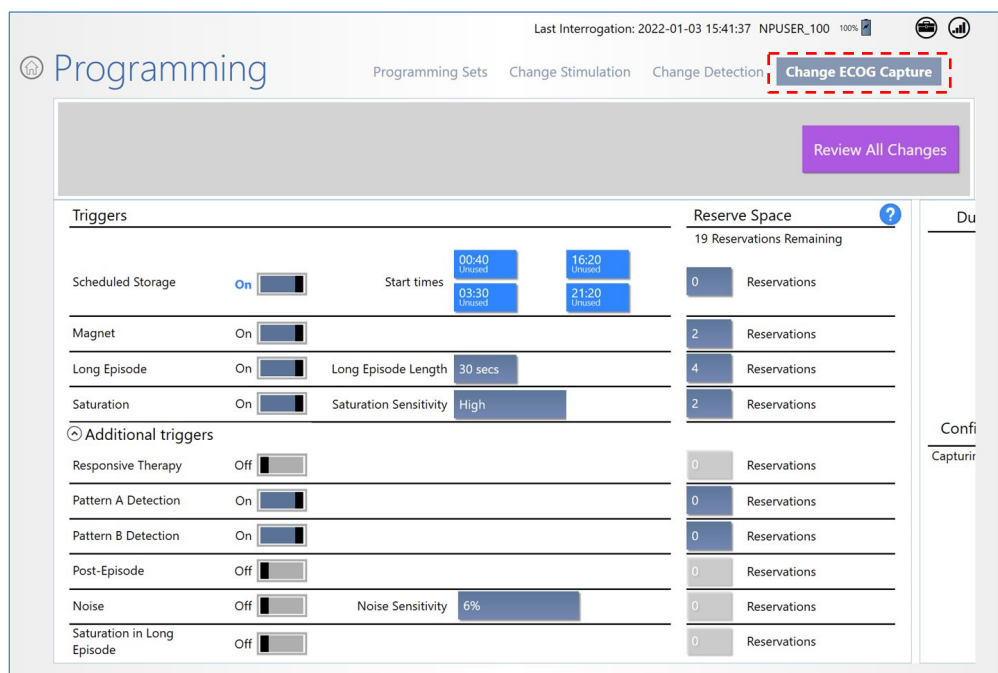


Figure 31 ECoG Capture screen, left side. Swipe left to see right side.

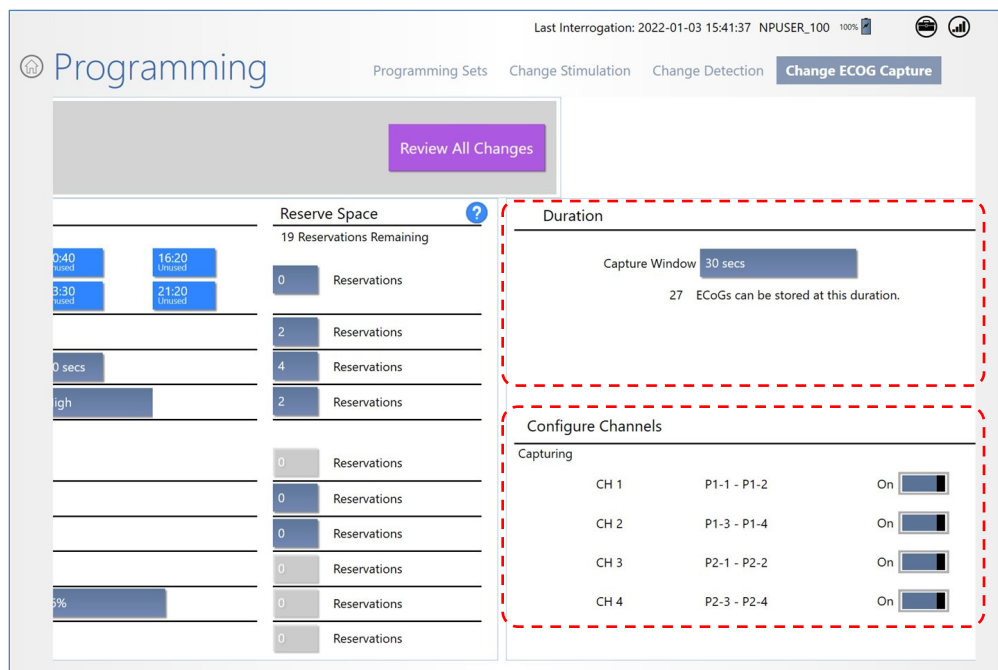


Figure 32 Right side of ECoG Capture screen

3. **Turn On Desired Channels:** In the **CONFIGURE CHANNELS** area at lower right, select the **ON/OFF** switch next to the desired **CHANNEL(S)** (**CH 1** through **CH 4**) to turn each channel on or off as desired. Only the channels selected **ON** will be recorded and stored.
4. **Set Capture Duration:** In the **DURATION** area at upper right (**Figure 32** above), select the **CAPTURE WINDOW** field and select one of the capture duration options. After your selection, the **DURATION** area shows the total duration (in seconds) and the number of ECoGs that can be stored at this duration.
5. **Set Capture Triggers:** In the **TRIGGERS** area at upper left (**Figure 31** above and **Figure 33** below), select the **ON/OFF** switch to turn **ON** the triggers that you wish to initiate ECoG capture.

Triggers		Reserve Space	
Scheduled Storage	Off	start times	Unused
			Unused
			Unused
			Unused
Magnet	On		1 reservations
Long Episode	On	Long Episode Length	30 secs
			2 reservations
Saturation	On	Saturation Sensitivity	High
			1 reservations
additional triggers			
Responsive Therapy	Off		0 reservations
Pattern A Detection	Off		0 reservations
Pattern B Detection	Off		0 reservations
Post-Episode	Off		0 reservations
Noise	Off	Noise Sensitivity	6%
			0 reservations

**Figure 33 Selecting ECoG Capture Triggers**

There are three recommended ECoG triggers to be programmed at implant. The first is a magnet swipe by the patient, which could indicate that a clinical seizure has occurred. The others are saturation (high amplitude ECoG) and long episode (sustained changes in the ECoG), both of which could indicate an electrographic seizure.

**Commonly Used Triggers:** The more commonly used triggers are listed first.

- **SCHEDULED STORAGE:** Initiate ECoG capture at up to four specific start times, which you can select using the fields to the right. Options are available in ten minute intervals using 24 hour time.
- **MAGNET:** Initiates ECoG capture when the patient swipes the magnet over the neurostimulator. If the patient swipes the magnet when they experience clinical symptoms, selecting this trigger may be helpful in evaluating these events.
- **LONG EPISODE:** Initiates ECoG capture when a detected episode exceeds the duration you select in the **LONG EPISODE LENGTH** field to the right. Duration options range from **1** to **120** seconds.

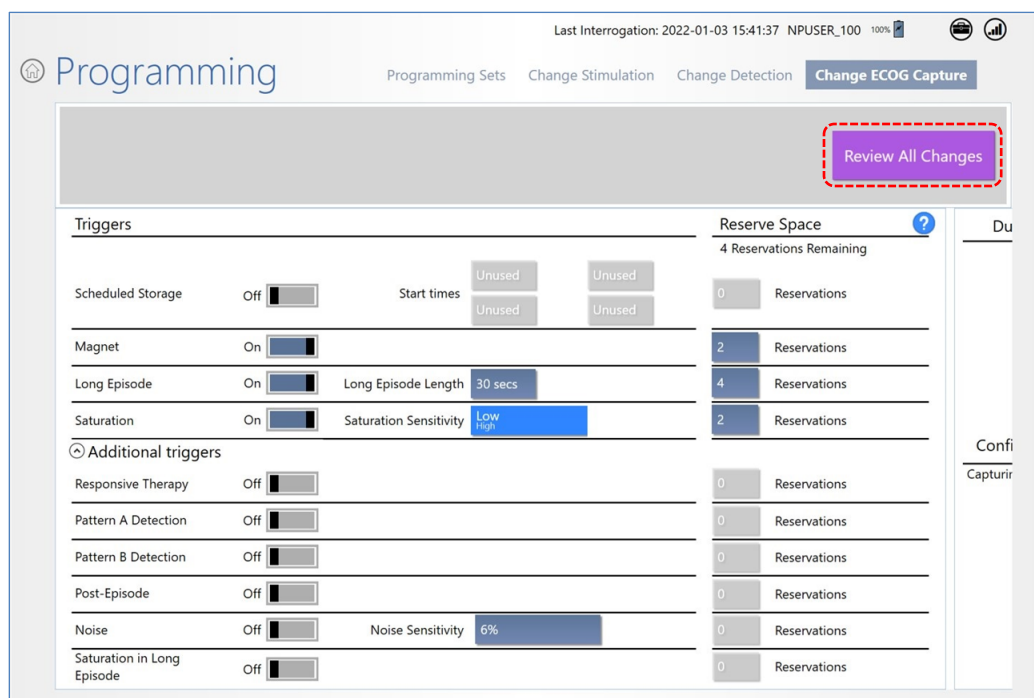
- **SATURATION:** Initiates ECoG capture when the ECoG amplitude exceeds the threshold associated with the value you select in the **SATURATION SENSITIVITY** field to the right. The sensitivity options are **High, Medium, Low** and **Off**. Selecting this trigger may be helpful in troubleshooting the RNS<sup>®</sup> System.

**Additional Triggers:** Select the down-arrow next to **ADDITIONAL TRIGGERS** at lower left to access the triggers below.

- **RESPONSIVE THERAPY:** Initiates ECoG capture when electrical stimulation therapy is delivered in response to a detected event. Selecting this trigger may be helpful in determining if therapy was delivered appropriately as well as evaluating the result of therapy delivered.
  - **PATTERN A DETECTION** and **PATTERN B DETECTION:** These are separate triggers; each initiates ECoG capture when a detected episode begins with the patterns designated as Pattern A and Pattern B on the **CHANGE DETECTION** screen. Selecting a pattern trigger may be helpful in evaluating the detection settings.
  - **POST-EPISODE:** Initiates ECoG capture at the end of a detected episode. Selecting this trigger may be helpful in evaluating activity after an episode.
  - **NOISE:** Initiates ECoG capture when the ECoG signal exceeds 60 Hz. Selecting this trigger may be helpful in troubleshooting the RNS<sup>®</sup> System.
  - **SATURATION IN LONG EPISODE:** Initiates ECoG capture when the ECoG amplitude exceeds the threshold selected in the **SATURATION SENSITIVITY** field during an episode that exceeds the duration selected in the **LONG EPISODE LENGTH** field.
6. **Set Reservations for Each Trigger:** In the **RESERVE SPACE** column to the right of each trigger (see **Figure 33** above), select the **reservations** field and select the number of reservations to make for each trigger. A reservation means that up to the specified number of ECoGs will be stored for that trigger, and can only be overwritten by newer ECoGs of the same trigger type. The total number of reservations available depends on the duration selected in the **DURATION** area at upper right.

### Recommended Initial ECoG Capture Settings

- **Configure Channels for Capturing:** All four channels **ON**
- **Duration:** **90 SECS**
- **Triggers On for ECoG Capture:**
  - **MAGNET:** Reservations = **2**
  - **LONG EPISODE:** Reservations = **4**, Long Episode Length = **30 SECS**
  - **SATURATION:** Saturation Sensitivity: **LOW**, Reservations = **2**
  - All other triggers **OFF**



**Figure 34 ECoG Capture showing recommended initial settings (left side only)**

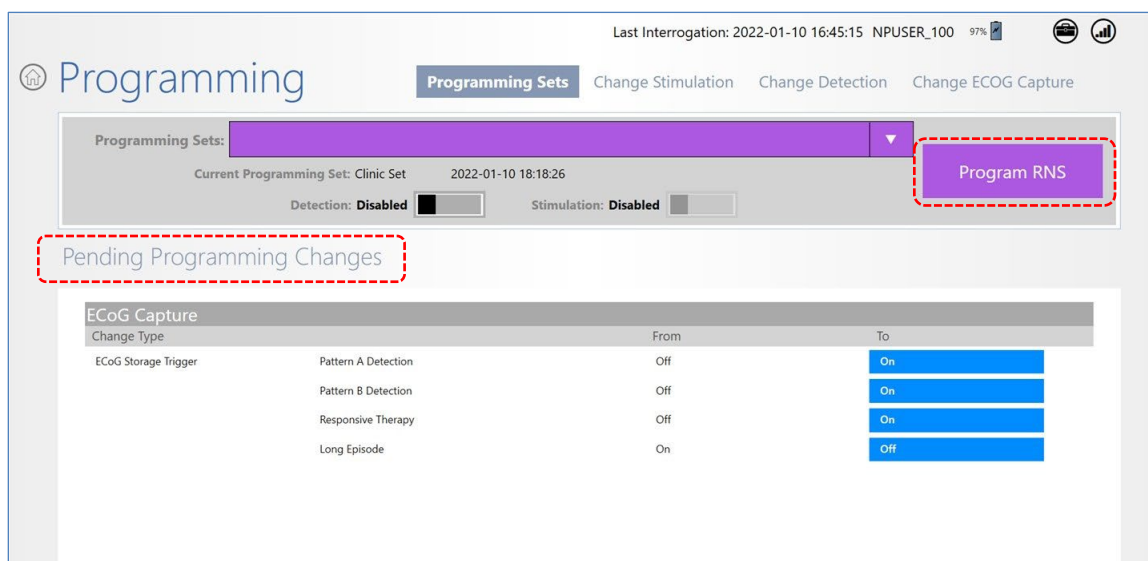
### **Program the Neurostimulator with the New Settings**

The new settings are not sent to the neurostimulator until you complete this step using the tablet in an interactive programming session.

- If you created ECoG capture settings on the PDMS, you must save it as part of a programming set and follow the instructions to **Share and/or Download a Programming Set** on page 71.

*Note: ECoG capture triggers are inactive during programming. **Programming clears activity information and ECoGs stored in the neurostimulator.** If there is any new information, be sure to interrogate the neurostimulator prior to programming.*

7. Select **REVIEW ALL CHANGES** at upper right. All **PENDING PROGRAMMING CHANGES** appear on the **PROGRAMMING SETS** screen for your review before programming. Scroll down if necessary to see all the changes.




---

**Figure 35 Pending Programming Changes for ECoG Capture**


---

8. If you are satisfied with the new or changed settings, place the wand within approximately 1 inch of the neurostimulator and select **PROGRAM RNS**. The **PROGRAMMING NEUROSTIMULATOR** dialog shows programming progress until complete.

If you are not satisfied with the pending changes, select the desired button to **CHANGE DETECTION**, **CHANGE STIMULATION** or **CHANGE ECoG CAPTURE**, and after making changes, select **REVIEW ALL CHANGES** and then **PROGRAM RNS**.

### RECOMMENDATION FOR REVIEW OF INITIAL ECoG CAPTURE SETTINGS

ECoGs stored by the RNS® Neurostimulator during the first several days after implantation of the neurostimulator and leads may not be representative of the patient's typical baseline activity. ECoG capture settings should be reviewed to ensure that the desired activity is being stored. If it appears that ECoGs containing the desired activity are being overwritten by later events, instruct the patient to use the remote monitor and wand to interrogate the neurostimulator immediately after each clinical seizure, or to interrogate several times per day. Several interrogations per day during the first several days after implantation will not have a significant impact on battery life.

- **Recommendation:** Review ECoGs on the PDMS to determine whether detections and storage are optimal. If not, consider adjustments to the following triggers recommended to be **ON** initially.
  - **LONG EPISODE LENGTH:** Adjust the duration that triggers capture of a long episode.
  - **MAGNET:** Consider turning **OFF** the **MAGNET** trigger if the patient is not able to apply the magnet before or immediately after a clinical seizure, or if ECoGs captured by this trigger are not useful. Magnet swipes will still be counted and reported in the diagnostics.
  - **DURATION:** Select a briefer **CAPTURE WINDOW** value to yield more stored ECoGs, or a lengthier value to yield fewer stored ECoGs.

If you make changes, be sure to follow the steps above to review and program the new settings into the neurostimulator.

## CONFIGURE DETECTION: DEFINE AND MODIFY DETECTION SETTINGS

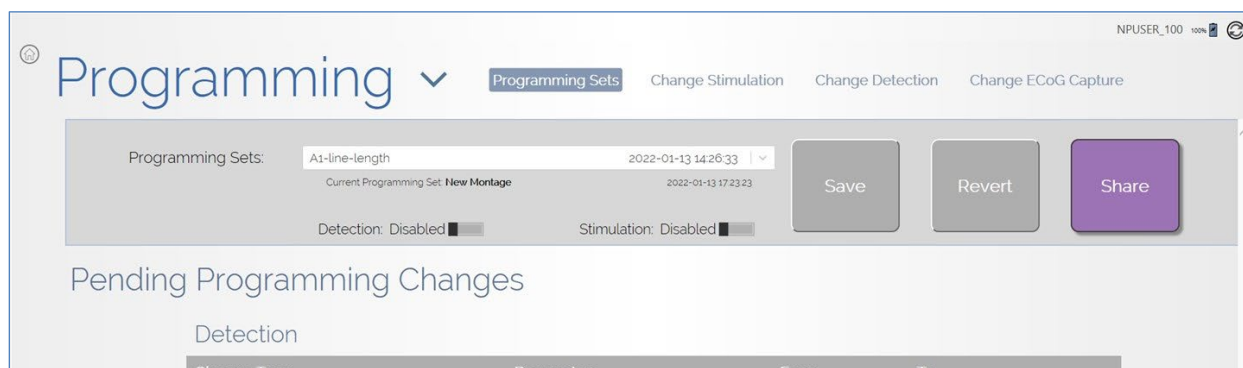
A programming set includes the settings for detection, stimulation, and ECoG capture. Detection settings are used by the RNS<sup>®</sup> Neurostimulator to recognize epileptiform activity as defined by the physician. To configure detection means to select specific ECoG patterns to be detected, and then to program the system to detect these patterns. Configuring detection is a prerequisite for electrical stimulation therapy, but it does not require you to enable therapy.

*Note: You must use the PDMS outside an interactive programming session to identify and select ECoG patterns to detect. When you select a pattern, the PDMS automatically simulates detection on all ECoGs stored for a patient. Simulation is displayed for groups of six ECoGs at a time, and you can navigate through all ECoGs for that patient.*

Configuring detection has three phases:

- **Phase 1: Select Default Detection Settings upon First Use** on page 50, you select one of the three default programming sets, which include default detection settings, to gather an initial collection of ECoGs. This is usually configured and programmed in the operating room immediately after implantation.
- **Phase 2: Define Detection Settings** on page 53, after initial ECoGs have been stored, you review the stored ECoGs and identify the specific ECoG patterns to be detected. Using the SimpleStart Feature, the system provides a starting point for this process. It is a tool to assist you as you exercise clinical judgment to define detection settings. It suggests a starting point only. It does not preempt nor replace your clinical judgment. This is usually programmed at the first visit post-implantation.

When saving is complete, you return to the **PROGRAMMING SETS** screen and the **SHARE** button is active. This new programming set will not be available to users and programmers until it is actively shared with them. A programming set becomes available for offline programming when it is shared and then downloaded locally to the programmer. For instructions, see **Share and/or Download a Programming Set** on page 71.



- **Phase 3: Customize Detection** on page 58, you repeat the process of reviewing stored ECoGs and adjusting the parameters of each pattern to optimize detection of ECoG activity for this patient. This is programmed at any visit after phase 2.

*Note: Changed settings are highlighted blue and new setting text is shown in larger font above the smaller previous setting. Gray or plain items have not changed.*

**To put these three phases in context:**

Immediately after implantation of the neurostimulator, you select a default programming set in **Phase 1**, in order to collect ECoGs with activity of interest specific to the patient, and ECoGs with baseline activity.

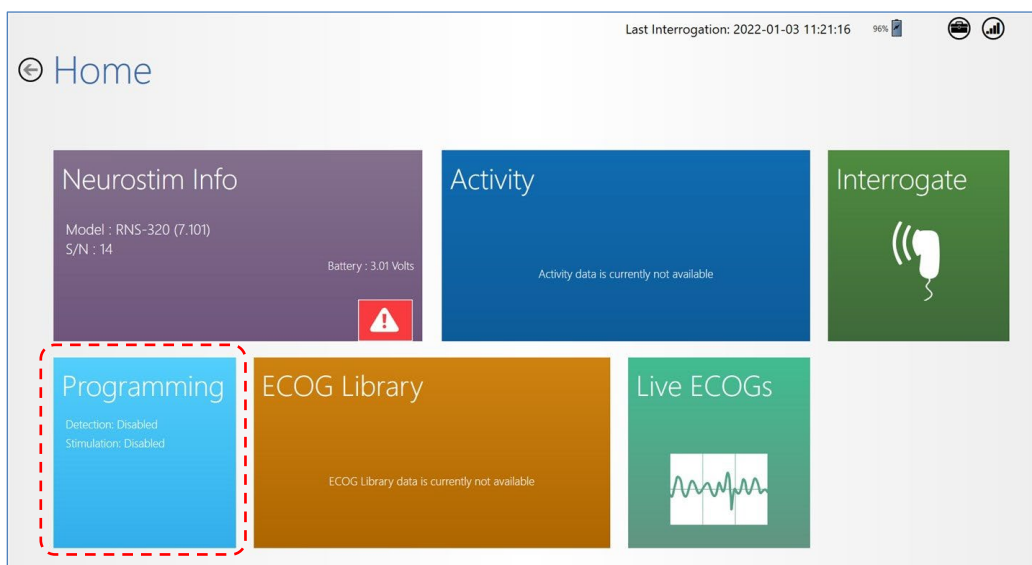
After collecting sufficient ECoGs, you identify the specific electrocorticographic patterns to be detected and then, in **Phase 2**, the system provides a starting point for establishing patient-specific detection settings. You may then modify the parameters of the suggested starting detection settings to make detection more or less sensitive, or to detect earlier or later.

In future visits, after collecting additional ECoGs, you then, in **Phase 3**, iterate to improve detection (and, once responsive therapy has been enabled, to improve clinical response) by making small, incremental changes to detection parameters with the sliders or **MORE CONTROLS**.

*Note: Typically, physicians repeat earlier phases (Phase 1 or Phase 2) only if they observe a new type of ECoG activity of interest that requires an additional detector; or if a good clinical response has not been obtained and they wish to start over.*

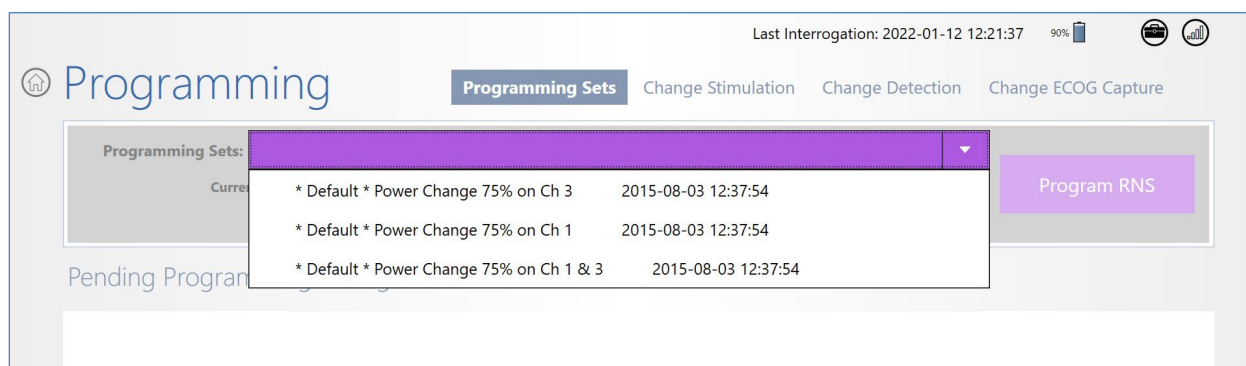
**Phase 1: Select Default Detection Settings upon First Use**

Upon first use of the tablet for each patient, the patient has no saved ECoGs from which to select a pattern for detection, and so you must select one of three default programming sets, which includes default detection and ECoG capture settings. This is usually configured in the operating room immediately after implantation. The default sets are used to gather an initial set of ECoGs for a patient, which you can then use in a subsequent visit to define detection settings specific to the patient. If you have already performed these steps once, proceed to the next section, **Phase 2: Define Detection Settings**.

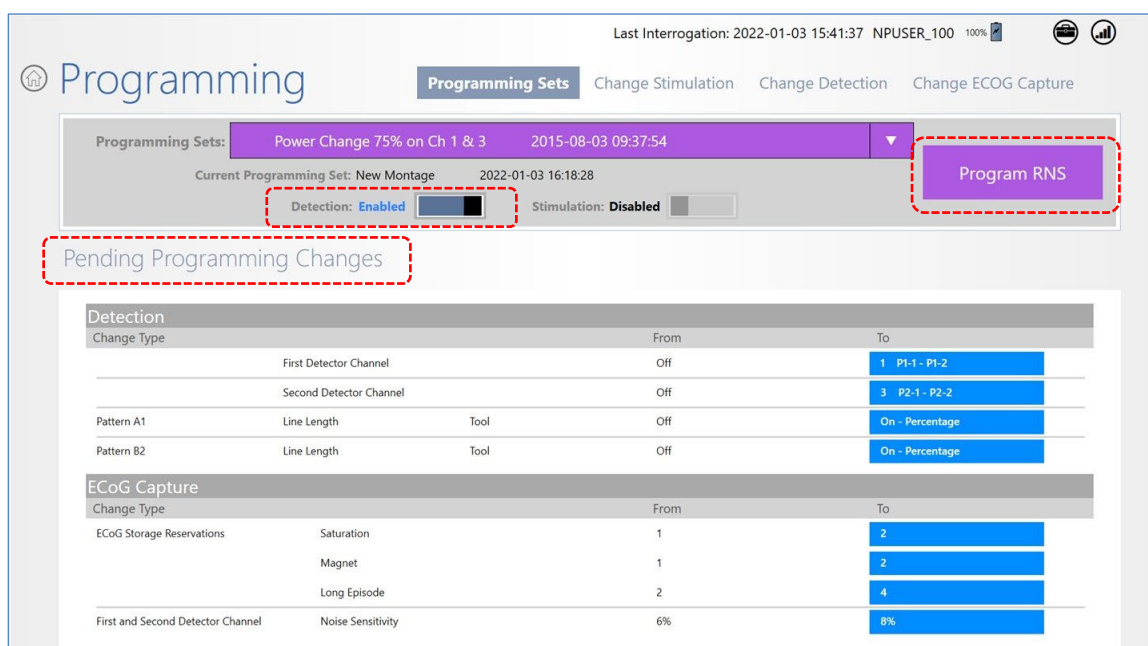


1. Select **PROGRAMMING** from the **HOME** screen.
2. On the **PROGRAMMING SETS** screen, select the down-arrow at the right end of the **PROGRAMMING SETS** field to view the available programming sets. The three default

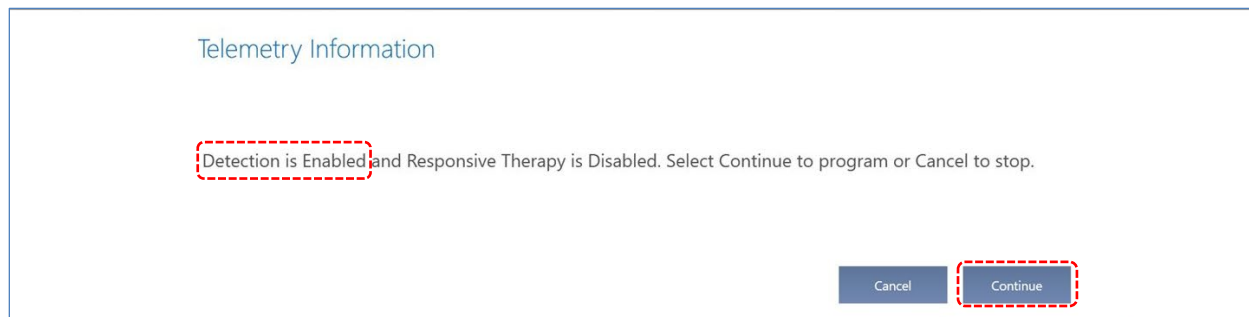
programming sets are named beginning with **\* Default \* Power Change 75% on Ch 3**. (If the programmer is connected to the Internet, **\* Default \*** does not appear before the name.)



3. Select one of the three default programming sets, which includes default detection settings. In the usual case, a patient has two active leads to be configured, and therefore the recommended default pattern is **POWER CHANGE 75% ON CH 1 & 3**. The other default patterns detect on only one lead.
  - Power Change 75% is a detection setting that captures any large changes in the signal that clinicians can program and optimize as detection patterns.
4. Make sure DETECTION is **Enabled**. Select the button next to DETECTION: **Disabled** to toggle the button to **Enabled**.

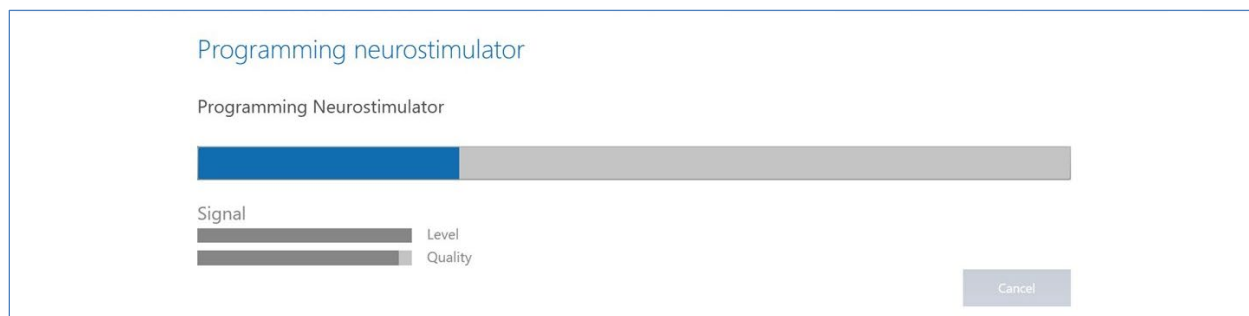


5. After reviewing the pending programming changes, if you are satisfied with the new settings, place the wand within approximately 1 inch of the neurostimulator and select **PROGRAM RNS**. A **TELEMETRY INFORMATION** dialog reports that “Detection is Enabled and Responsive Therapy is Disabled,” and prompts you to select **CONTINUE** or **CANCEL**.

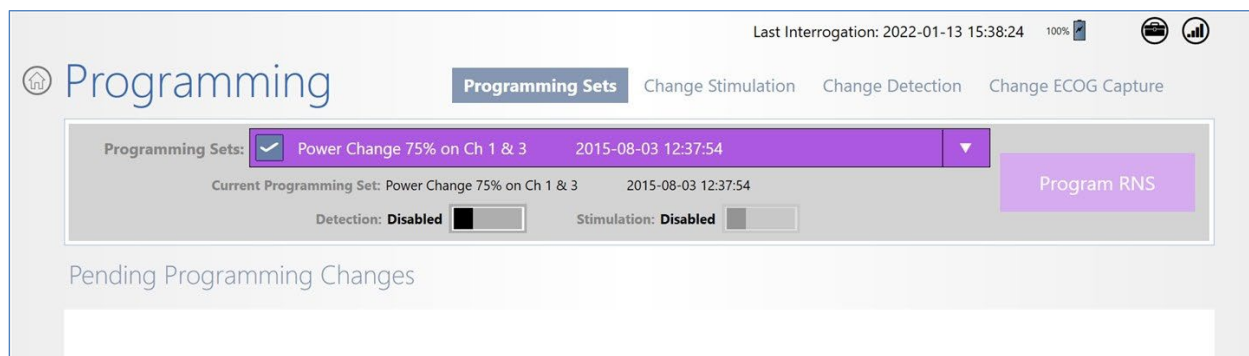


**Figure 36 Telemetry Information dialog to confirm programming**

6. Make sure the message reports that **DETECTION** is **ENABLED**, keep the wand in place and select **CONTINUE** to proceed with programming, or **CANCEL** to cancel programming and return to the previous screen. When you select **CONTINUE**, the **PROGRAMMING NEUROSTIMULATOR** dialog shows programming progress until complete.



**Figure 37 Programming neurostimulator dialog shows progress of programming**



**Figure 38 Programming Sets screen after programming a default programming set**

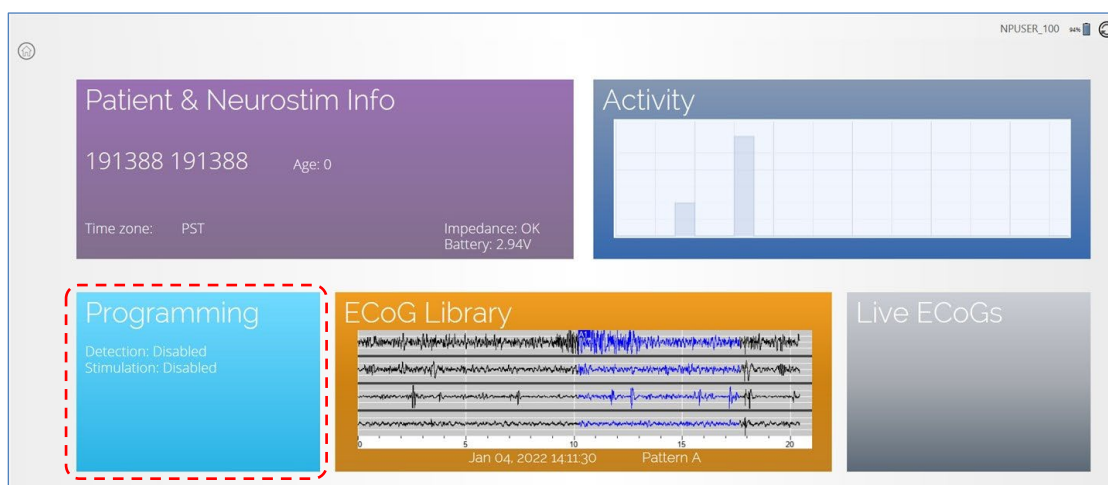
When complete, the **PROGRAMMING SETS** field shows the name of the programmed default detection set with a checkmark next to it, no pending programming changes and an inactive **PROGRAM RNS** button. The checkmark indicates the current programming set in use on the neurostimulator.

## Phase 2: Define Detection Settings

*Note: For this phase, you must use either the PDMS via web browser on a personal computer; or via the tablet outside an interactive programming session. This means you cannot select an epileptiform pattern to detect, nor simulate detection on saved ECoGs, during an interactive programming session with a patient's neurostimulator. After interrogating any neurostimulator, an interactive programming session persists on the tablet until you go back to the Start screen. Then select the **PATIENT LIST** tile. In the **PATIENT LIST** screen, you can select the desired patient and proceed to define detection settings. Detection settings are saved as part of a new programming set.*

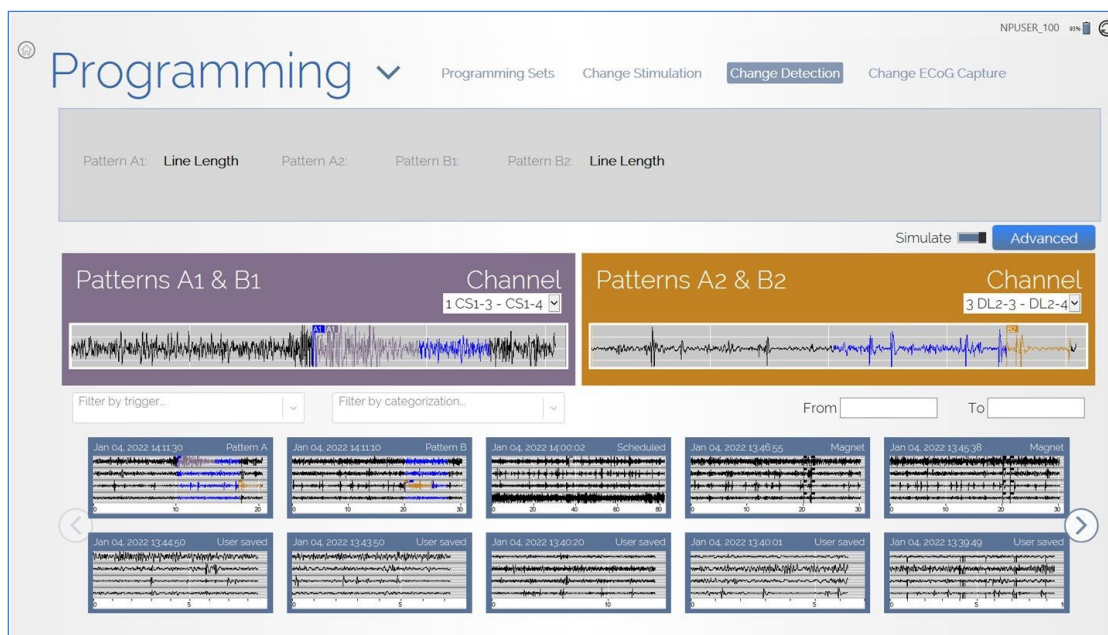
At this point, the patient should have ECoGs stored in the PDMS from which to select specific patterns for detection. Detection settings consist of the ECoG patterns defined and saved as part of a programming set. A pattern defines the type of ECoG activity to be detected. You can define up to four patterns to detect, two patterns on each of two channels. The patterns defined on a specific channel can operate only in that selected ECoG channel. Follow these steps to define detection settings.

1. Using the PDMS (outside an interactive programming session), go to the **PATIENT LIST** (through the **PATIENT LIST** tile on the tablet) and select the patient whose detection settings you will define or change. The **PATIENT HOME** screen opens. Note this is different than the tablet **HOME** screen (shown in **Figure 9** on page 22).



**Figure 39 Patient Home screen**

2. Select **PROGRAMMING** from the **PATIENT HOME** screen. The **PROGRAMMING** screen opens. On the **PROGRAMMING** screen, select **CHANGE DETECTION** at upper center. The **CHANGE DETECTION** screen opens.



**Figure 40 Change Detection screen**

- The upper half of the screen provides tiles to select the current detection patterns and channels; the tiles are named **PATTERNS A1 & B1** (upper left) and **PATTERNS A2 & B2** (upper right).
  - The lower half of the screen shows thumbnails of all ECoGs (if no filters are on) stored in the PDMS that were captured using the current recording montage. (ECoGs stored in the PDMS were uploaded after interrogations from the remote monitor or programmer.) You can filter the ECoGs shown using the **TRIGGERS** and **CATEGORIES** menus at left center, and/or by date range using the **FROM** and **TO** fields at middle right.
  - The **SIMULATE** button at upper right (next to **ADVANCED**) is switched **ON** (blue) by default, which enables simulations of detections to be shown on all ECoGs shown on this screen.
3. Use the **DEFINE PATTERNS** dialog to define or modify detection settings. There are two routes to the **DEFINE PATTERNS** dialog.
    - Select one of the two **PATTERN** tiles, **PATTERNS A1 & B1** or **PATTERNS A2 & B2**, to go there directly, or
    - Select one of the ECoG thumbnails at the bottom to open its ECoG dialog, which is named by its date and trigger type, and then select one of the two **MODIFY** buttons (**A1 & A2**, **B1 & B2**) at upper right. (You can also use the ECoG dialog to assign the ECoG to a category if desired.)

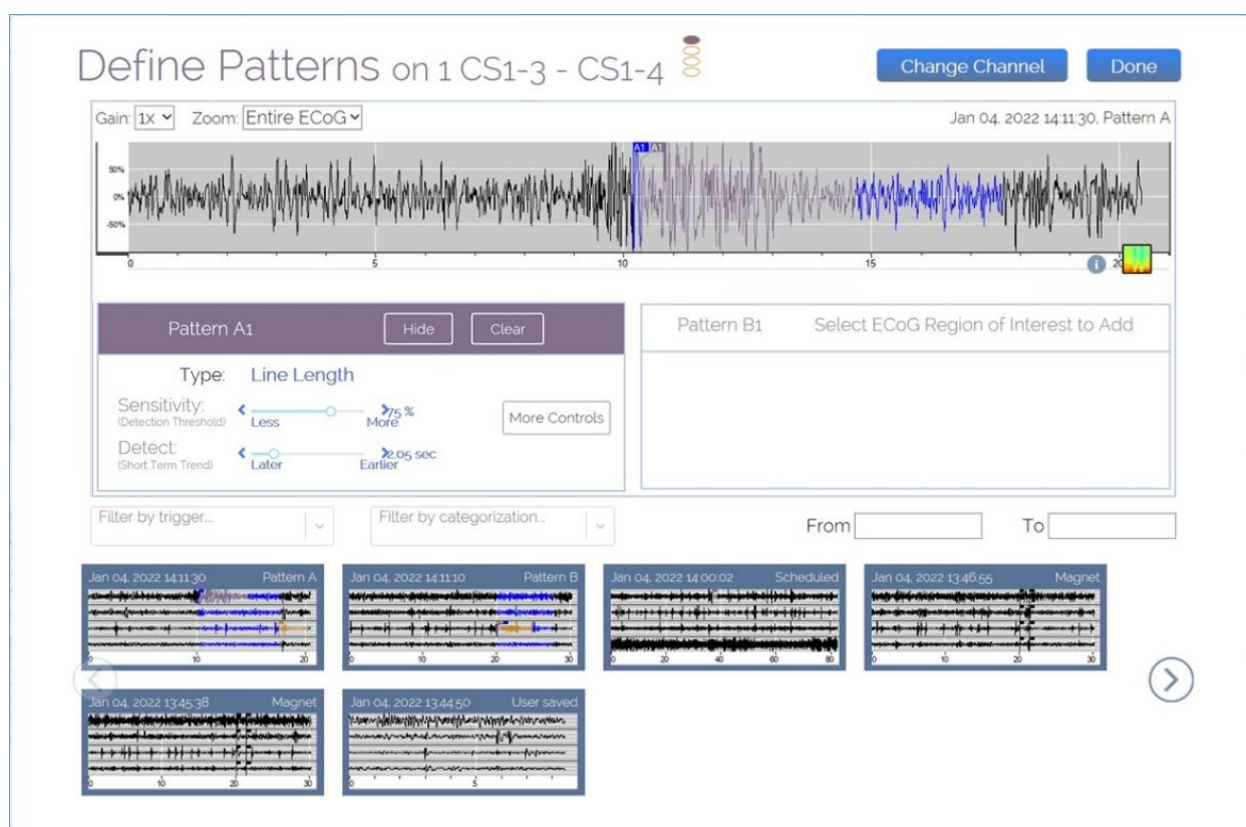
### If You Selected a New ECoG First

- If you selected a new ECoG first and selected a **MODIFY** button, a **SELECT CHANNEL** dialog opens. Touch within the channel that has a pattern to detect. Then the **DEFINE PATTERNS** dialog opens.

### Using the Define Patterns Dialog

*Note: A pattern defines the type of ECoG activity to be detected.*

- In the **DEFINE PATTERNS** dialog, the upper portion shows the ECoG in the selected channel. Touch on the point of the ECoG where you would like detection to occur. Starting from the point where you touch, a 3-second window of time (or region of interest, ROI) is bracketed on the ECoG. This touch feature to bracket a 3-second region of interest is called the SimpleStart Feature.



**Figure 41 Define Patterns dialog**

- The 3-second window bracketed on the ECoG is the pattern you are identifying for detection; it should contain the type of pattern you would like to detect.
- Each 3-second window is identified as one of the four possible patterns you can define, **A1**, **A2**, **B1** or **B2**. (The 1 and 2 indicate the first and second ROI you select. Typically the A and B patterns are defined on different leads.)

- You can touch on the (ROI) window identifier (**A1**, **A2**, **B1** or **B2**) and slide the window left or right to place it where it gives the desired simulated detection results. Note that the software may apply a different suggested detection tool when you move the window.

*Note: You cannot select a 3-second window within the first 5 seconds of an ECoG, because the software looks for differences in the ECoG data before the 3-second window and needs sufficient preceding data to determine this difference. If you touch before 5 seconds in the ECoG, the software places the window starting at the 5-second mark.*

- Normally you want to touch near the beginning of the pattern in order to define a pattern that will be detected promptly after it begins. Detection settings should promptly detect ECoG activity and not detect on baseline activity.

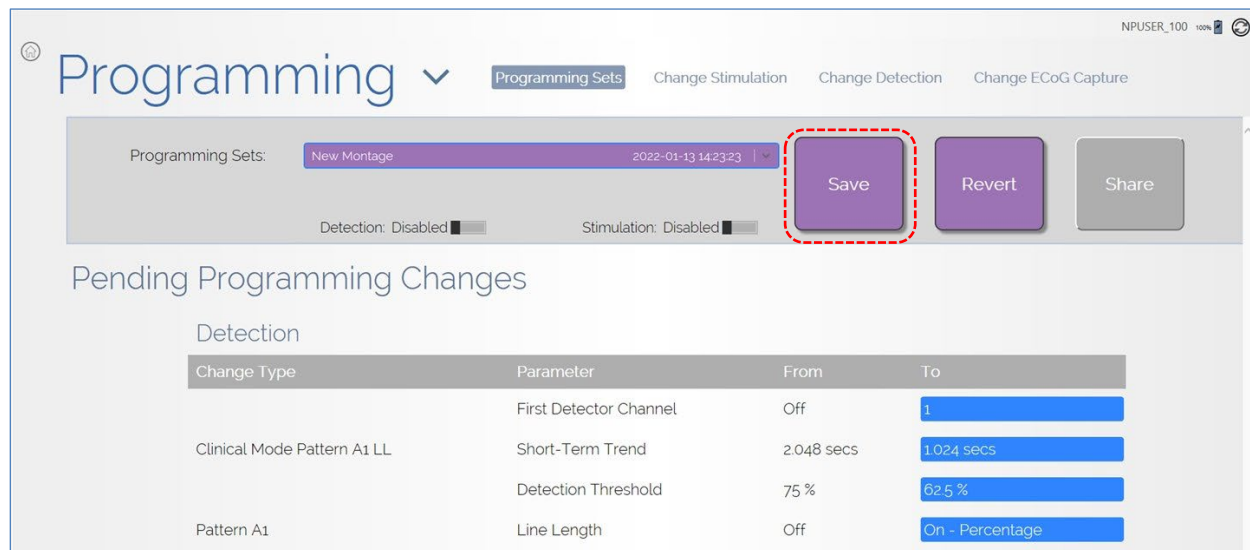
The software automatically applies a suggested type of detector (shown next to **TYPE**) and settings that fit the waveform pattern in that 3-second window (or region of interest, ROI), and simulates detection, showing the detection flags the chosen pattern would apply to this ECoG—and to all the patient's other stored ECoGs shown in smaller size below. It is recommended to review simulated detection activity on an ensemble of stored ECoGs before finalizing the detection settings.

- To hide the simulation on the ECoG, select **HIDE**. To remove the selection on the ECoG, select **CLEAR**.
- At any point, you can select a different ECoG by selecting an ECoG thumbnail along the bottom; select the right arrow or left arrow at the corresponding end of the screen to see all available thumbnails.
- By default, if you define both patterns, detections will occur for both patterns on this channel. The channel is indicated by the filled oval at top center of the dialog, from 1 to 4 top to bottom. Use the **CHANGE CHANNEL** button to change the channel on which to detect the pattern.

*Note: If simulating performance of 2-channel detection settings, be sure to select ECoGs that contain ECoG activity patterns you wish to detect in both channels.*

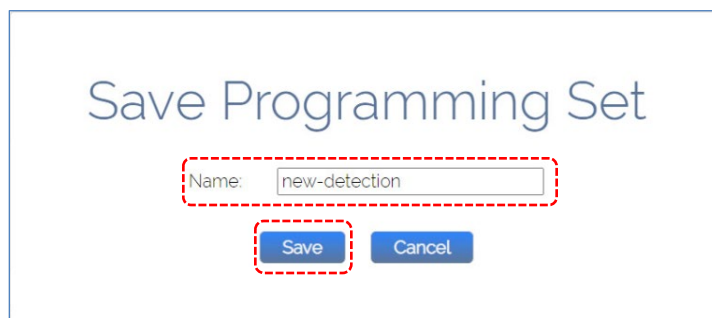
- Make adjustments to the parameters applicable to the detection tool using the sliders available and observe the effects on the simulation. For **SPIKE ACTIVITY** and **RHYTHMIC ACTIVITY**, the sliders adjust **AMPLITUDE** (%) and **DURATION** (seconds). For **LINE LENGTH**, the sliders adjust **SENSITIVITY** (%) and **DETECT** (seconds).
  - All these detection parameters affect sensitivity. Adjustments that increase sensitivity tend to increase how early and how often the pattern is detected; adjustments that decrease sensitivity tend to decrease how early and how often the pattern is detected.
  - Detection settings should be programmed for early detection of activity. Detection settings that result in early activity detection usually also result in numerous detections; this is expected and acceptable behavior.
  - The parameter values are shown to the right of each slider. For all four parameters, lower values result in greater sensitivity.
- The **MORE CONTROLS** button gives access to **Optional Advanced Settings for Detection on the PDMS** (see page 61).

6. Select **DONE** at upper right to close the **DEFINE PATTERNS** dialog. You return to the **CHANGE DETECTION** screen.
7. Select **REVIEW ALL CHANGES**, which returns you to the **PROGRAMMING SETS** screen and shows all **PENDING PROGRAMMING CHANGES**. Scroll down if necessary to see all the changes.

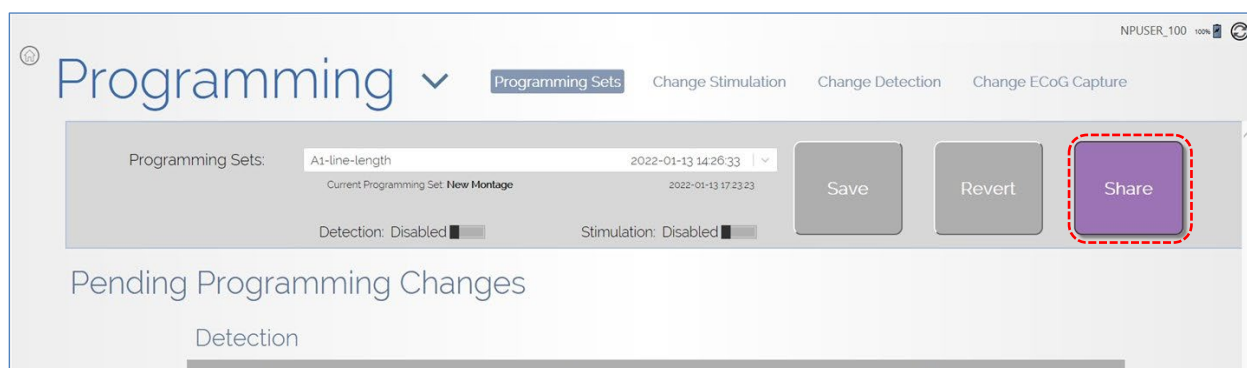


**Figure 42 Pending programming set ready to be saved**

8. Select **SAVE** and name the programming set in the **SAVE PROGRAMMING SET** dialog that opens, and then select **SAVE** in the dialog.



When saving is complete, you return to the **PROGRAMMING SETS** screen and the **SHARE** button is active. This new programming set will not be available to users and programmers until it is actively shared with them. A programming set becomes available for offline programming when it is shared and then downloaded locally to the programmer. For instructions, see **Share and/or Download a Programming Set** on page 71.



### **Phase 3: Customize Detection**

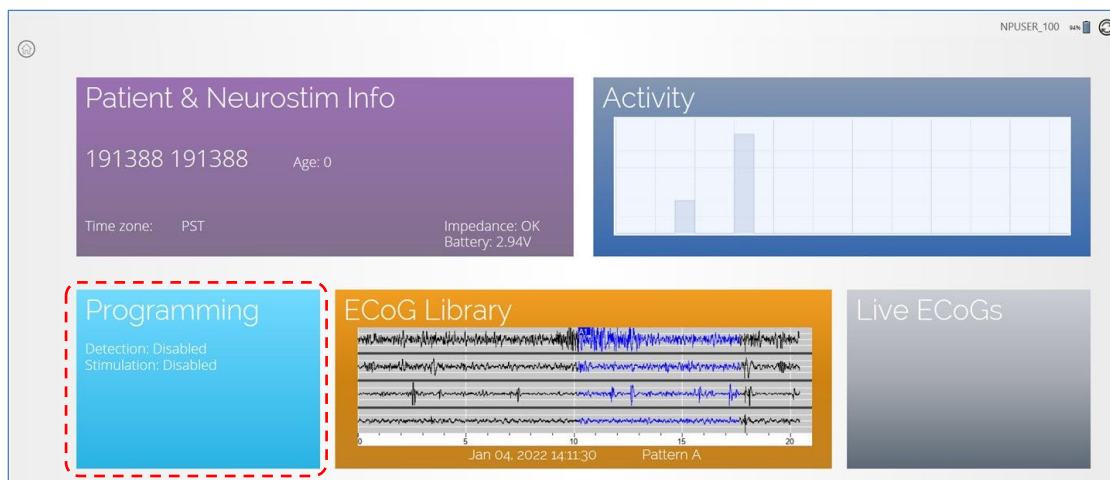
To customize detection is to refine detection settings to promptly detect the specific patterns for this patient, and not detect on baseline activity, since detection serves as the basis for neurostimulator treatment. On visits subsequent to **Phase 2: Define Detection Settings** the usual, systematic approach is to make small, incremental adjustments to individual parameters of a detection pattern. The adjustment you make may be intended to increase or decrease how early and how often the pattern is detected, based on your assessment of current detection activity as viewed on stored ECoGs and on the **Activity Screen** (see page 28).

*Note: Typically, physicians repeat earlier phases (Phase 1 or Phase 2) only if they observe a new type of ECoG activity of interest that requires an additional detector; or if a good clinical response has not been obtained and they wish to start over.*

#### **Recommended: Change and Simulate Detection Settings Before Patient Visit on the PDMS**

To have full control of detection settings, it is recommended that clinicians will prepare detection settings (as part of a programming set) before a patient's follow-up visit. In this way, the clinician can review the proposed detection changes through simulated detection on the patient's previously saved ECoGs. To do this, you must use either the PDMS via web browser on a personal computer, or via the tablet outside an interactive programming session.

1. Using the PDMS (outside an interactive programming session), go to the **PATIENT LIST** (through the **PATIENT LIST** tile on the tablet) and select the patient whose detection settings you will change. The **PATIENT HOME** screen opens. Note this is different than the tablet **HOME** screen (shown in **Figure 9** on page 22).

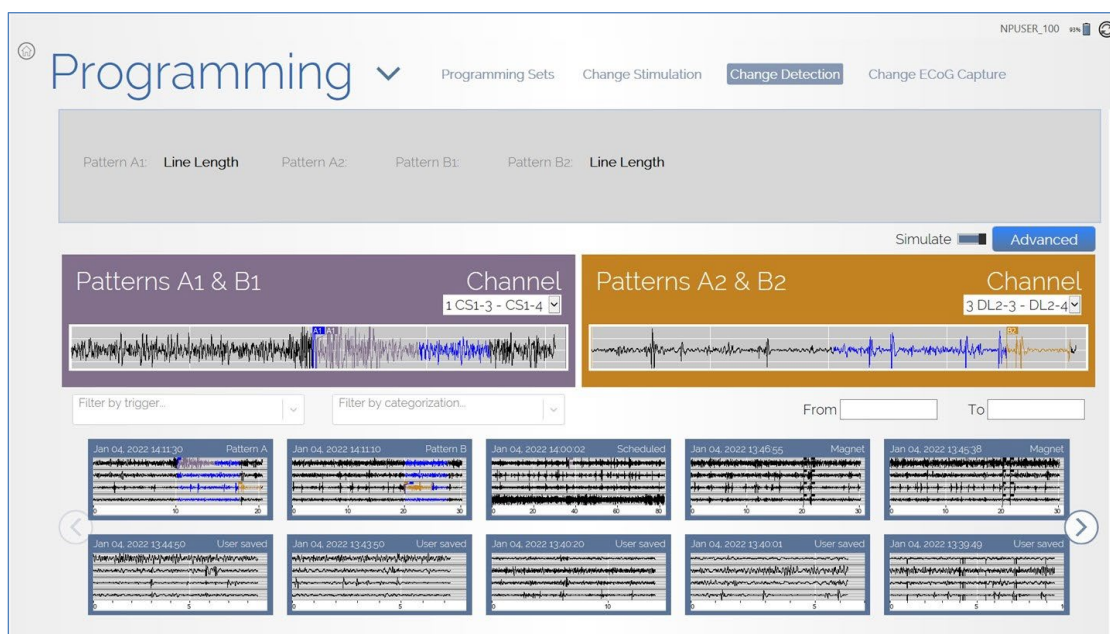



---

**Figure 43 Patient Home screen**


---

2. Select **PROGRAMMING** from the **PATIENT HOME** screen. The **PROGRAMMING** screen opens. On the **PROGRAMMING** screen, select **CHANGE DETECTION** at upper center. The **CHANGE DETECTION** screen opens.



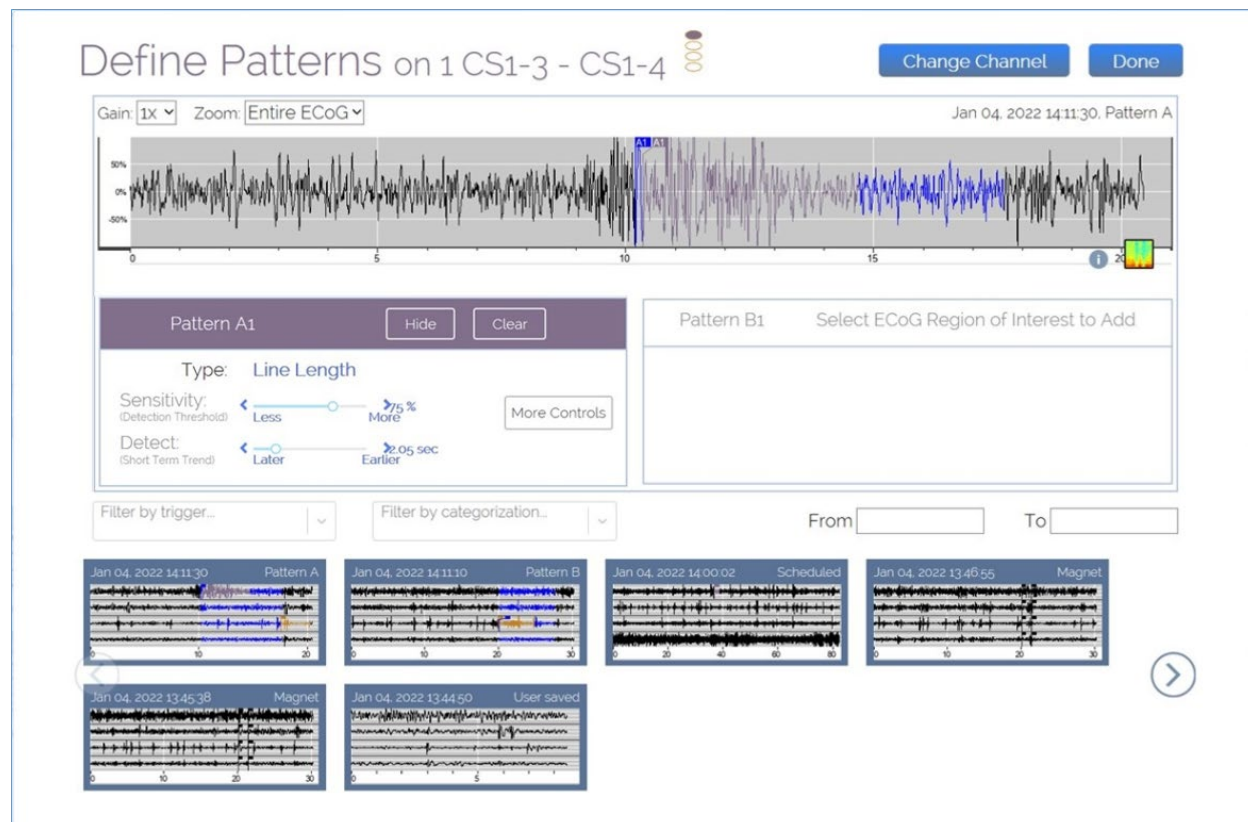

---

**Figure 44 Change Detection screen on the PDMS (outside an interactive programming session)**


---

- The upper half of the screen provides tiles to select the current detection patterns and channels; the tiles are named **PATTERNS A1 & B1** (upper left) and **PATTERNS A2 & B2** (upper right).
- The lower half of the screen shows thumbnails of all ECoGs (if no filters are on) stored in the PDMS that were captured using the current recording montage. You can filter the ECoGs shown using the **TRIGGERS** and **CATEGORIES** menus at left center.

- The **SIMULATE** button at upper right (next to **ADVANCED**) is switched **ON** (blue) by default, which enables simulations of detections to be shown on all ECoGs shown on this screen.
3. Select one of the two **PATTERN** tiles at the top to access the **DEFINE PATTERNS** dialog.



**Figure 45 Define Patterns dialog**

4. In the **DEFINE PATTERNS** dialog, select and adjust the desired parameter using the sliders so as to increase or decrease how early and how often the pattern is detected.

The software automatically simulates detection with the changed parameter as applied to this ECoG and to the patient's other stored ECoGs shown in smaller size below. It is recommended to review simulated detection activity on an ensemble of stored ECoGs before finalizing your adjustment.

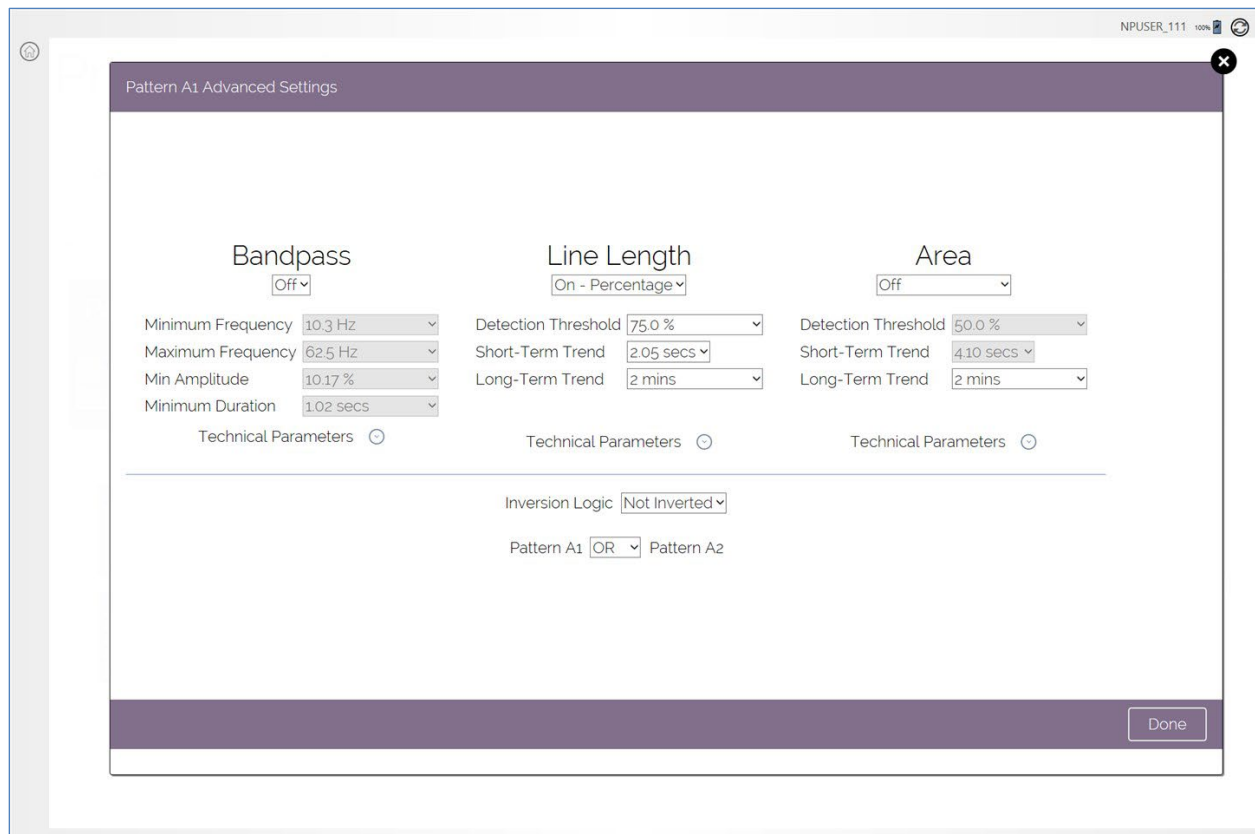
- If necessary, scroll to view the bottom of the dialog where the ECoGs appear with simulated detection; use the right arrow or left arrow button to see more ECoGs if available. You can filter the ECoGs using the **TRIGGERS** and **CATEGORIES** menus, and/or the **FROM** and **TO** date range fields.
- To hide the simulation on the ECoG, select **HIDE**. To remove the pattern on the ECoG, select **CLEAR**.
- Detection parameters that affect sensitivity are key: adjustments that increase sensitivity tend to increase how early and how often the pattern is detected; adjustments that decrease sensitivity tend to decrease how early and how often the pattern is detected.

- To adjust sensitivity, the two most common parameters to adjust are the ones with sliders directly on the **DEFINE PATTERNS** dialog. For **SPIKE ACTIVITY** and **RHYTHMIC ACTIVITY**, the sliders adjust **AMPLITUDE (%)** and **DURATION (seconds)**. For **LINE LENGTH**, the sliders adjust **SENSITIVITY (%)** and **DETECT (seconds)**.

*Note: The parameter values are shown to the right of each slider. For all four parameters, lower values result in greater sensitivity. Make adjustments and observe the effects on the simulation.*

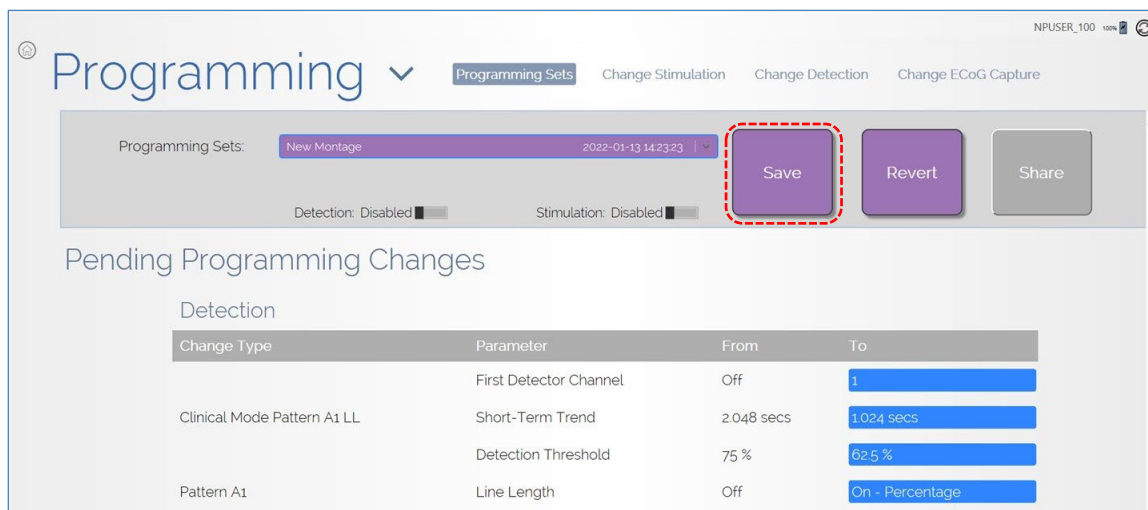
#### Optional Advanced Settings for Detection on the PDMS

- Select **MORE CONTROLS > ADV SETTINGS** to open the **ADVANCED SETTINGS** dialog for the pattern you are currently defining, which gives access to additional settings for the detection tools **BANDPASS**, **LINE LENGTH** and **AREA**. (**AREA** can be selected only in this dialog.) Select the down-arrow next to **TECHNICAL PARAMETERS** to access even more settings. You can select more than one tool for use at the same time in this dialog.



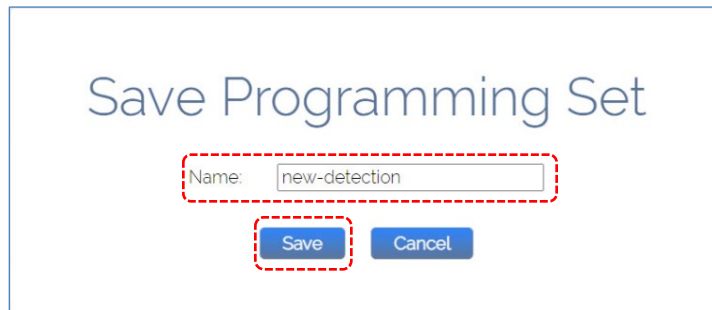
**Figure 46 Advanced Settings dialog on the PDMS (outside interactive programming)**

- Select **DONE** at bottom or the circle-X (exit) button at upper right to close the **ADVANCED SETTINGS** dialog.
- When finished making changes in the **DEFINE PATTERNS** dialog, select **DONE** at upper right to close it.
  - Select **REVIEW ALL CHANGES**, which returns you to the **PROGRAMMING SETS** screen and shows all **PENDING PROGRAMMING CHANGES**. Scroll down if necessary to see all the changes.

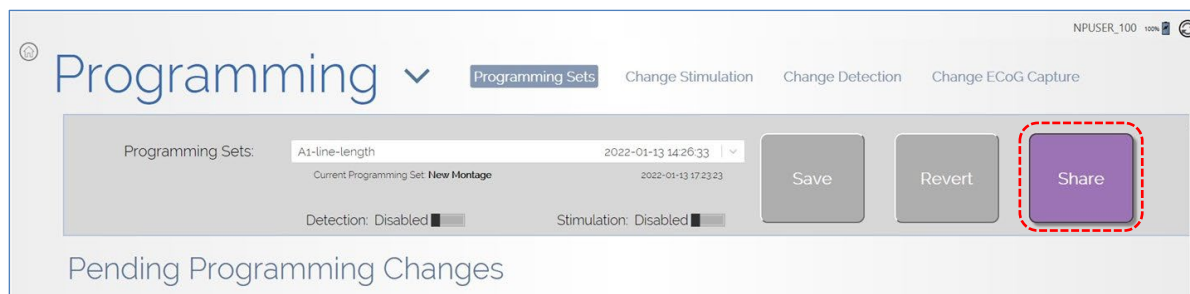


**Figure 47 Pending programming set ready to be saved**

- Back in the **PROGRAMMING SETS** screen, the **SAVE** and **REVERT** buttons are now active. To remove all changes to the programming set, select **REVERT**. The **REVERT PROGRAMMING SETTINGS** dialog opens. Select **REVERT** to confirm your choice, or **CANCEL** to go back.
7. Select **SAVE** and name the programming set in the **SAVE PROGRAMMING SET** dialog that opens, and then select **SAVE** in the dialog.

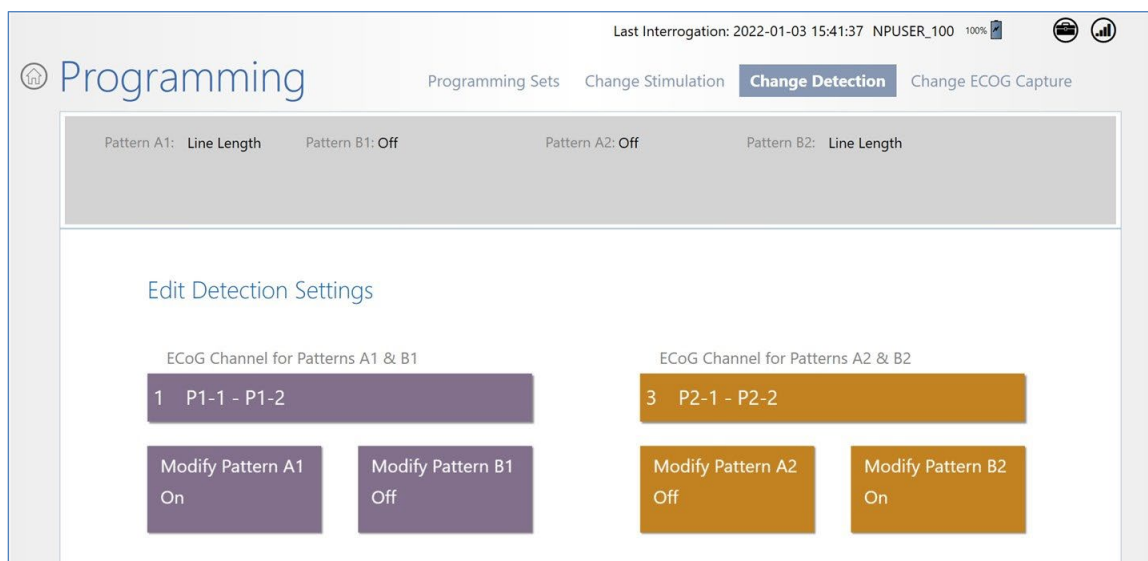


When saving is complete, you return to the **PROGRAMMING SETS** screen and the **SHARE** button is active. This new programming set will not be available to users and programmers until it is actively shared with them. A programming set becomes available for offline programming when it is shared and then downloaded locally to the programmer. For instructions, see **Share and/or Download a Programming Set** on page 71.



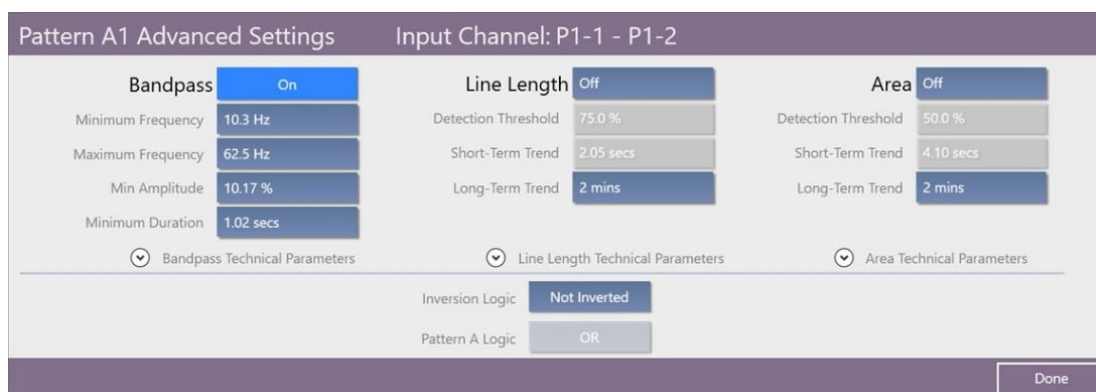
### Change Detection During Interactive Programming on the Tablet

*Note: During an interactive programming session, the **CHANGE DETECTION** screen allows you to change advanced settings only. This means you cannot select an epileptiform pattern to detect from a patient's saved ECoGs, nor simulate detection on all the patient's saved ECoGs, during an interactive programming session with a patient's neurostimulator.*



**Figure 48 CHANGE DETECTION screen during interactive programming on the tablet**

- Select **ECOG CHANNEL FOR PATTERNS A1 & B1**, or **ECOG CHANNEL FOR PATTERNS A2 & B2**, to select a different channel for those patterns or to turn the channel off.
- To access advanced settings that you can change manually for each pattern, select one of the four colored tiles to **MODIFY PATTERN A1, B1, A2, or B2**. This opens the **ADVANCED SETTINGS** dialog, which gives access to additional settings for the detection tools **BANDPASS**, **LINE LENGTH** and **AREA**. (**AREA** can be selected only in this dialog.) Select the down-arrow next to **TECHNICAL PARAMETERS** to access even more settings. You can select more than one tool for use at the same time in this dialog.



**Figure 49 Advanced Settings dialog during interactive programming**

- Select **DONE** at lower right to close the dialog when finished making changes. Your changes will be retained back in the **PROGRAMMING SETS** screen, where you can review the **PENDING PROGRAMMING CHANGES**. If satisfied, select **PROGRAM RNS** to program the resulting programming set, automatically named “Clinic Set” with date and time, into the neurostimulator. The Clinic Set will be saved on the PDMS also, if and when the programmer is connected to the Internet.

## DETECTION TOOLS AND DETECTORS

*Note: Detection tools and detectors support you as you exercise clinical judgment to define detection settings. Detectors and settings initially suggested by the software (as described in **Phase 2: Define Detection Settings** on page 53) offer a starting point only. The software does not preempt nor replace your clinical judgment.*

When you select a waveform pattern to detect, the SimpleStart software feature suggests a detector (one of **LINE LENGTH**, **RHYTHMIC ACTIVITY** or **SPIKE ACTIVITY**) and associated settings as a proposed fit for that pattern. You use this procedure initially (in **Phase 2: Define Detection Settings**, see page 53) to create new detection settings when you have first gathered ECoGs containing the type of activity you wish to detect. These detection settings are a suggested starting point to assist you as you exercise clinical judgment to define detection settings. It suggests a starting point only. It does not preempt nor replace your clinical judgment. The software also simulates the suggested detector and settings on all of the patient’s stored ECoGs. By reviewing the simulated detection on an ensemble of stored ECoGs, you can confirm that detection occurs when desired, or change the selected pattern, detectors and/or settings to make detection occur when desired. Having defined up to four detection patterns and associated settings, you then save these detection settings as part of a programming set. (Up to four detection patterns on up to two channels comprise the detection settings.)

### Detection Tools and Detectors

The RNS® Tablet uses three kinds of detection tools: **LINE LENGTH** or **POWER CHANGE** (page 65), **BANDPASS** (page 69), and **AREA** (page 70).

- The **LINE LENGTH** detection tool is used in the **POWER CHANGE** detector. The terms are used interchangeably in the programmer software.
- The **BANDPASS** detection tool is used in two detectors, **RHYTHMIC ACTIVITY** and **SPIKE ACTIVITY**.
- The **AREA** detection tool is infrequently used and can be selected only manually from the **DEFINE PATTERNS** dialog (select **MORE CONTROLS > ADV SETTINGS**).

*Note: **RHYTHMIC ACTIVITY** and **SPIKE ACTIVITY** both are types of ECoG activity that can be detected by the **BANDPASS** tool. The **AREA** tool is not used to generate a suggested detector from an ROI, but can be manually programmed by selecting **MORE CONTROLS > ADV SETTINGS**.*

The table below summarizes this information.

Detection Tool	Detectors Used With
<b>LINE LENGTH</b>	Power Change (or Line Length)
<b>BANDPASS</b>	Rhythmic Activity and Spike Activity
<b>AREA</b>	Area (configured manually only, not used as a suggested detector)

**Power Change Detector**

To understand how the power change detector works refer to **Figure 51**. Imagine the ECoG as a string that can be stretched so the length can be measured. ECoGs with higher amplitude or frequency oscillations will have longer length.

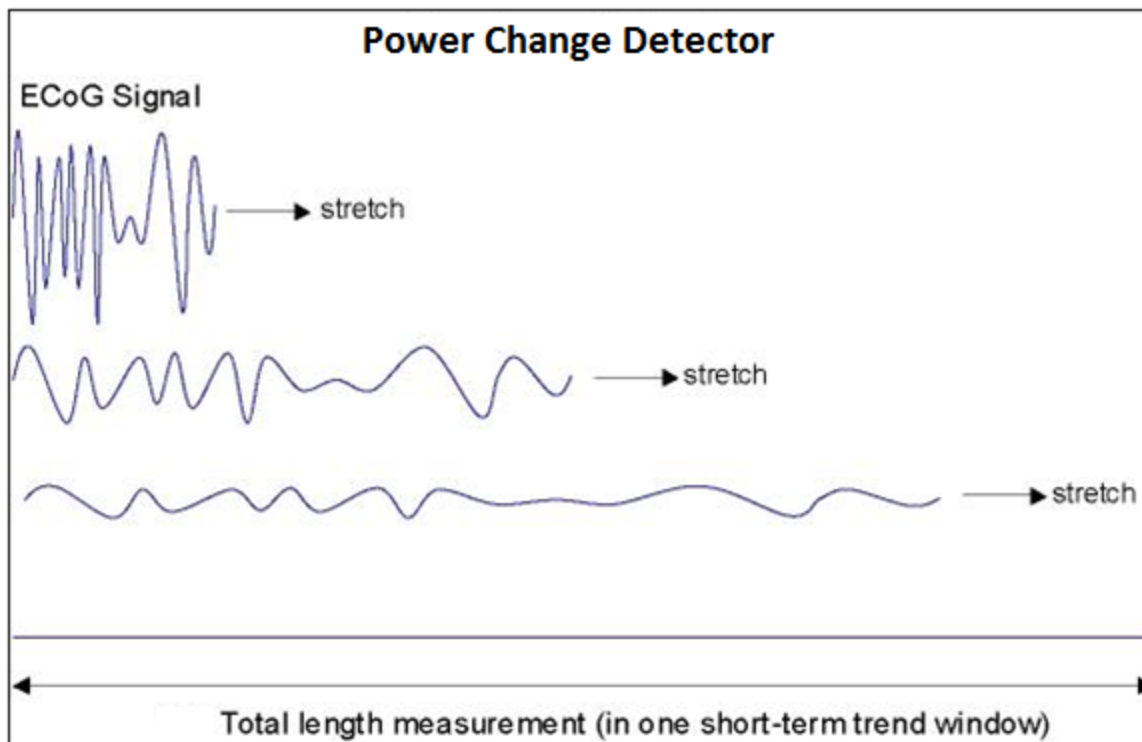
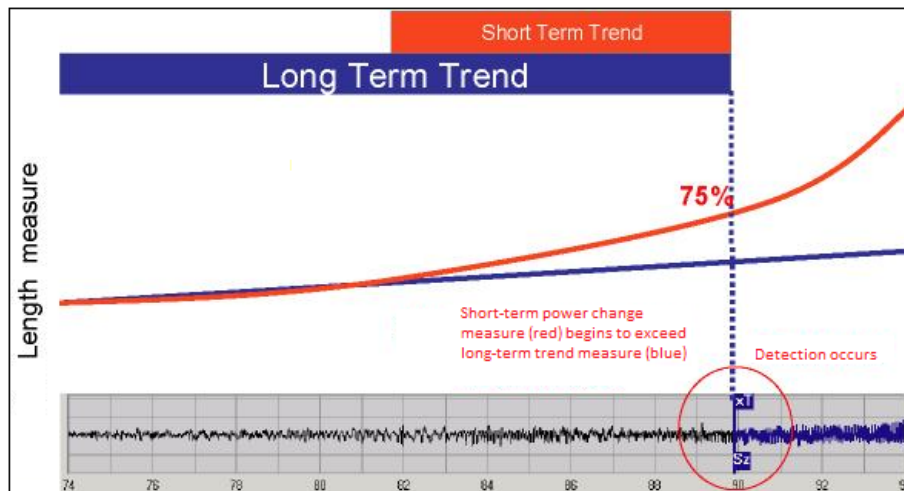


Figure 50 An illustration of the Power Change (or Line Length) detector

The ECoG in the bottom of **Figure 51** below shows a developing seizure that corresponds in time with the short-term power change trend line (red) and the long-term power change trend line (blue). The power change detector works by comparing the normalized ECoG length (length per second) in a short-term trend window (typically 1 to 4 seconds, red line in graph) to the normalized ECoG length in a long-term trend window (typically 1 to 2 minutes, blue line in graph).

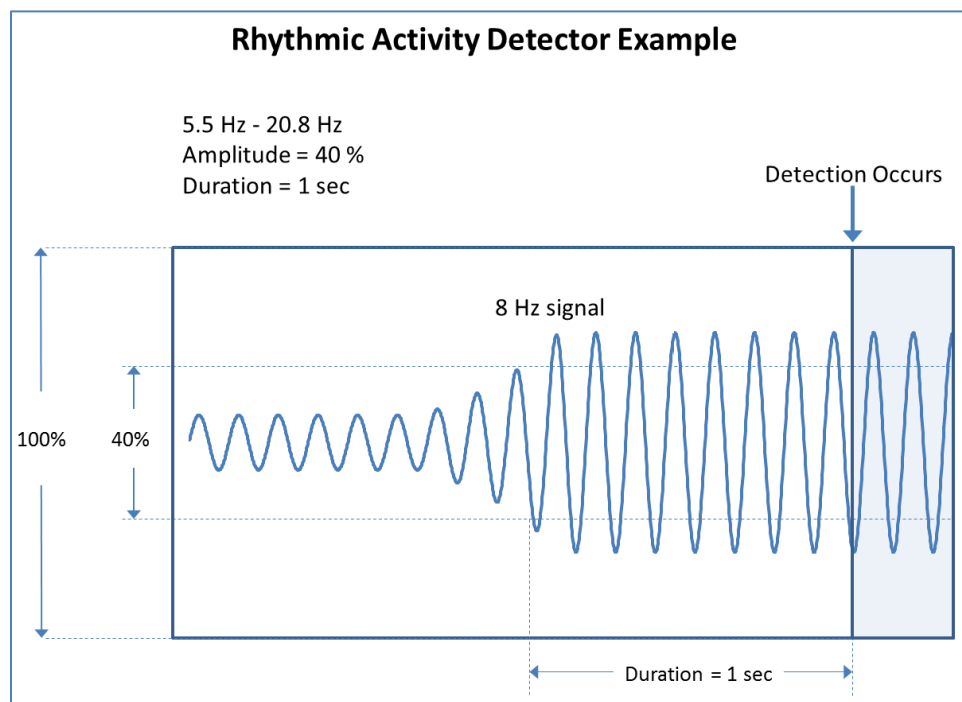


**Figure 51** Power Change detector example

Detection occurs when the difference between the short-term and long-term trend windows exceeds a programmed **SENSITIVITY** percentage (typically 37.5% to 100%). Lower **SENSITIVITY** settings result in earlier and more frequent detections. The **DETECT** setting specifies the length of the short-term trend (in seconds). Shorter **DETECT** settings result in earlier and more frequent detections.

### **Rhythmic Activity Detector**

The Rhythmic Activity detector provides highly specific and early detection of rhythmic activity within a defined bandwidth. It acts like a frequency filter and can therefore be used to detect activity within specific frequency bands (theta, alpha, beta, and gamma). To understand how the Rhythmic Activity detector works refer to **Figure 52**.

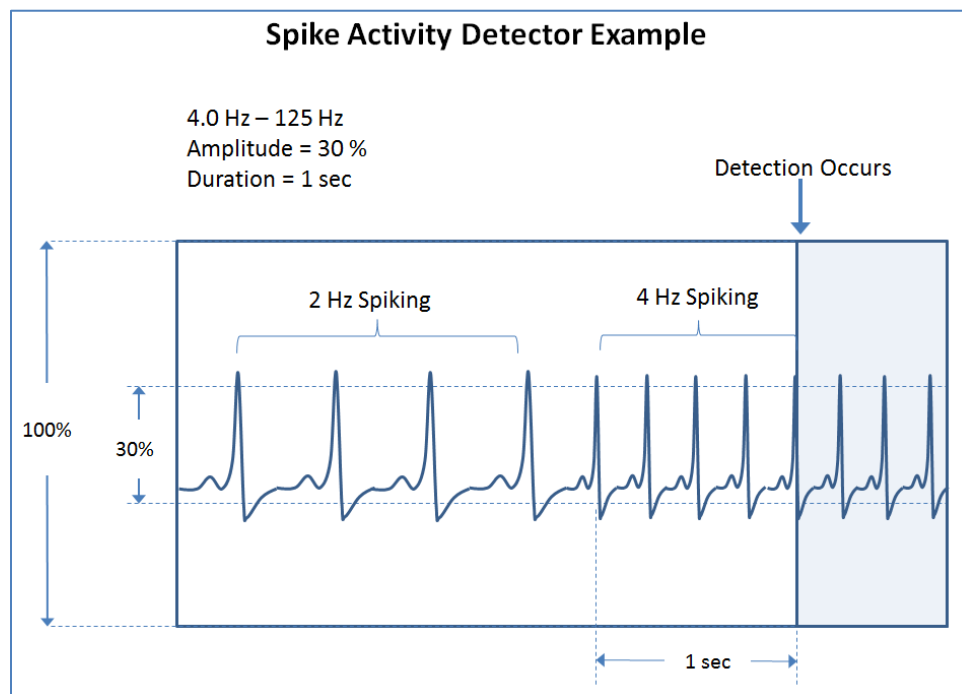


**Figure 52 Rhythmic Activity detector example**

The Rhythmic Activity detector analyzes the ECoG to determine when a signal is present within a specified bandwidth that meets specified amplitude and duration requirements. Four configurable parameters define the Rhythmic Activity detector operation: the **MINIMUM FREQUENCY** and **MAXIMUM FREQUENCY** that define the bandpass, the **AMPLITUDE**, and the **DURATION**. Detection occurs when a signal within the bandwidth exceeds the **AMPLITUDE** for the minimum **DURATION**. As **DURATION** is increased, the detector becomes less sensitive because it will take longer for a signal at a given frequency to be detected. As **DURATION** is decreased, the detector becomes more sensitive because it will take less time for a signal at a given frequency to be detected. As **AMPLITUDE** is increased, the detector becomes less sensitive because lower amplitude signals will be rejected. As **AMPLITUDE** is decreased, the detector becomes more sensitive because lower amplitude signals will be accepted.

### **Spike Activity Detector**

The Spike Activity detector functions in a manner very similar to the Rhythmic Activity detector, but it is optimized for the faster transients that comprise spikes. To understand how the Spike Activity detector works refer to **Figure 53**.



**Figure 53 Spike Activity detector example**

The Spike Activity detector analyzes the ECoG to determine when a signal is present within a specified bandwidth that meets specified amplitude and duration requirements. Four configurable parameters define the Spike Activity detector operation: the **MINIMUM FREQUENCY** and **MAXIMUM FREQUENCY**, the **AMPLITUDE**, and the **DURATION**. The **MINIMUM FREQUENCY** defines the slowest spiking rate that can be detected. The **MAXIMUM FREQUENCY** defines the upper passband for the detector. Because the signal frequency content of the fast transient portions of spikes are generally much higher than the spike rate, the **MAXIMUM FREQUENCY** usually needs to be set much higher than the spike rate. Detection will occur when spikes meeting the frequency requirements also exceed the **AMPLITUDE** for the **DURATION**. As **DURATION** is increased, the detector becomes less sensitive because it will take longer for detection to occur. As **DURATION** is decreased, the detector becomes more sensitive because it will take less time for a detection to occur.

### **Bandpass Detection Tool**

The Bandpass detection tool provides highly specific and early detection of rhythmic and spiking activity. It acts like a frequency filter and can therefore be used to detect activity within specific frequency bands (for example, theta, alpha, beta, and gamma). The **RHYTHMIC ACTIVITY** and **SPIKE ACTIVITY** detectors use the Bandpass tool.

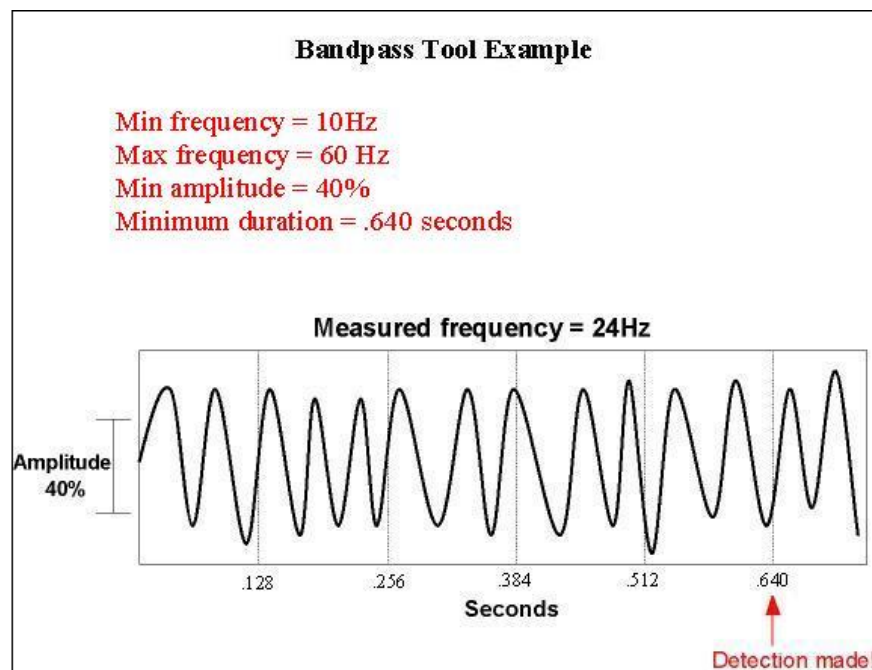
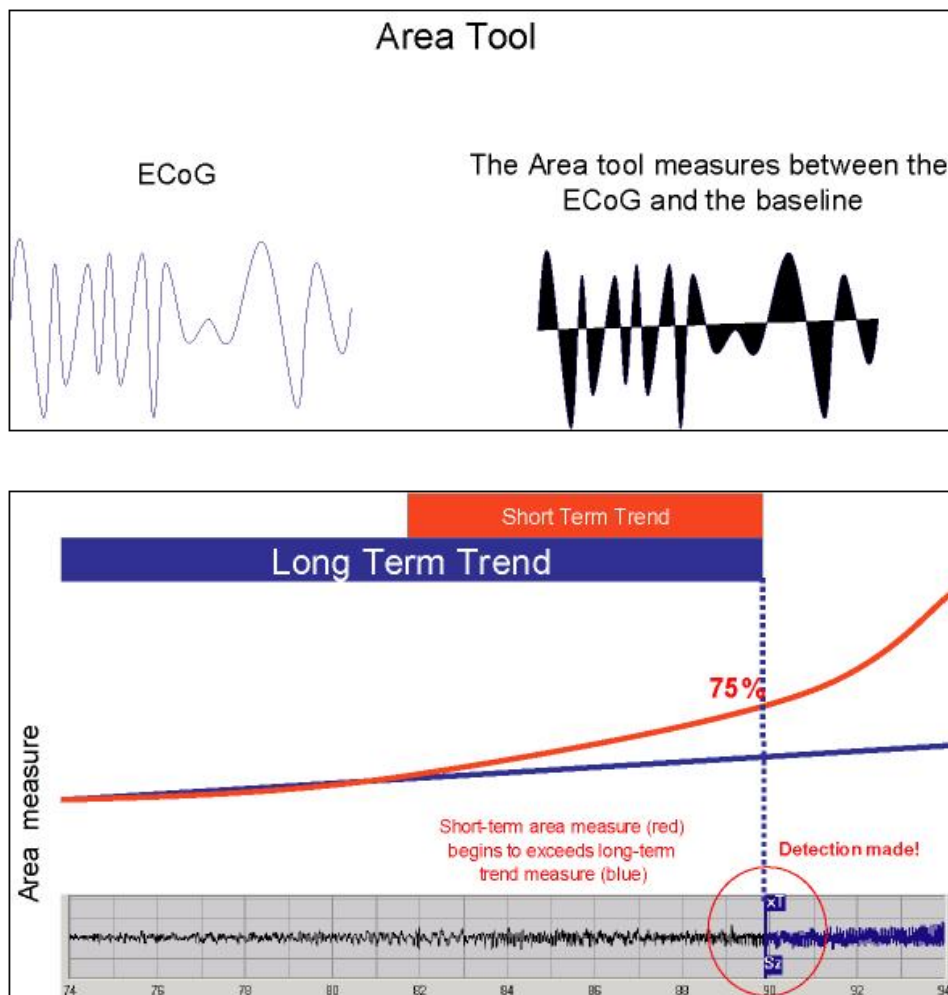


Figure 54 Bandpass detection tool example.

### Area Detection Tool

The **AREA** detection tool can be selected only manually from the **DEFINE PATTERNS** dialog (select **MORE CONTROLS > ADV SETTINGS**). It is not used as a suggested detector by the software. The **AREA** detection tool measures the area between the ECoG and the time axis (see **Figure 55**).



**Figure 55** Area detection tool example

The Area detector operates by comparing the normalized ECoG area (area per second) in a short-term trend window (typically 1 to 4 seconds) to the normalized ECoG area in a long-term trend window (typically 1 to 2 minutes). Detection occurs when the difference between the short-term and long-term trend windows exceeds a programmed threshold (typically 37.5% to 100%).

## SHARE AND/OR DOWNLOAD A PROGRAMMING SET

This section explains how to share a programming set with specific users or any programmer used to interrogate the patient, and how to download a shared programming set for offline use.

Programming sets created on the PDMS are saved to the PDMS only—not locally. You must actively share any programming set saved on the PDMS to make it available to anyone for programming, including yourself. For example, use this feature when more than one physician is treating a patient.

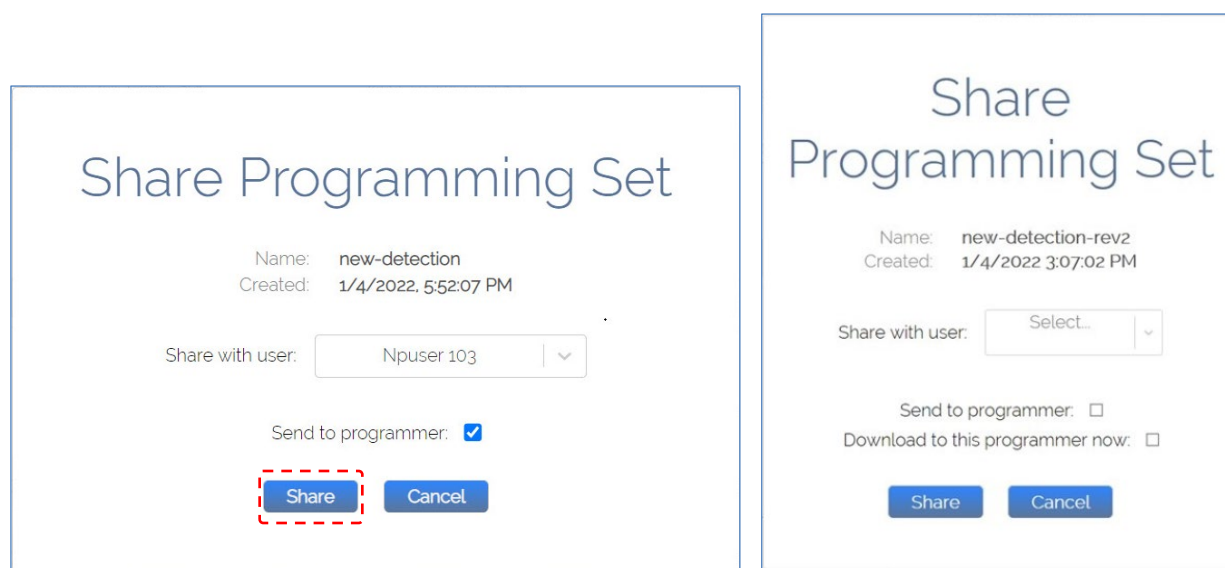
*Note: To access shared programming sets on the tablet, you must be connected to the PDMS (via the Internet). If not, you can select a default programming set or a programming set previously downloaded to the tablet. You can modify any available programming set before programming the RNS. If you are not connected to the Internet, see **Connect to the Internet for PDMS Access** on page 11.*

If you are connected to the PDMS during programming, you can program the neurostimulator with any programming set shared with you or with any programmer that has interrogated the target patient's neurostimulator. However, if you are not connected to the PDMS (offline) during programming, you can program only the pre-programmed default programming sets or those programming sets previously downloaded from the PDMS to the programmer.

*Note: When a patient's custom programming set will be programmed where there is no Internet connectivity, it is necessary to download the custom programming set from the Patient List to the tablet before use offline. Follow the **Steps to Download a Programming Set to the Tablet** on page 74.*

### Steps to Share a Programming Set

1. While working on the PDMS (outside an interactive programming session), you can share the currently selected programming set by selecting the active **SHARE** button on the **PROGRAMMING SETS** screen. (The **SHARE** button will not be active if the selected programming set has already been programmed to the neurostimulator.) The **SHARE PROGRAMMING SET** dialog opens. On a programmer, the dialog is narrower and includes the option to **DOWNLOAD TO THIS PROGRAMMER NOW**.



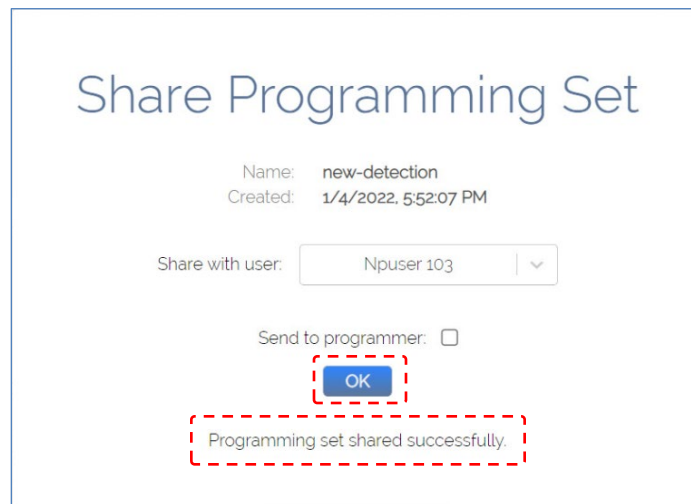
**Figure 56** The **SHARE PROGRAMMING SET** dialog on the PDMS: on a web browser (left), on the tablet (right)

2. You can select available checkboxes in any combination to share according to these options:
  - a. **SHARE WITH USER:** Select to share with a specific user, who could then access it on any programmer or desktop to which he is logged in. Touch the field to select from a list of available usernames, if any. (Available usernames include those users authorized for access to the patient to which the programming set applies.)
  - b. **SEND TO PROGRAMMER:** Select to share with any programmer used to interrogate the neurostimulator associated with the patient to which the programming set applies. This is the target patient's neurostimulator.
  - c. **DOWNLOAD TO THIS PROGRAMMER NOW:** Select to save the programming set locally to this programmer now, whereupon it will be available for offline use (where there is no Internet connection) after interrogation of the target patient's neurostimulator.

*Note: This option can be used to download a custom programming set, so it can be programmed where there is no Internet connection. See **Steps to Download a Programming Set to the Tablet for Offline Use** on page 74. A downloaded programming set is only available for offline use; it is not available if the programmer is connected to the PDMS.*

3. When you have selected a user or programmer or both to share with, select the **SHARE** button in the **SHARE PROGRAMMING SET** dialog.

When sharing completes, a message on the dialog reports **PROGRAMMING SET SHARED SUCCESSFULLY**. Click **OK** to close the dialog and return to the **PROGRAMMING SETS** screen.



---

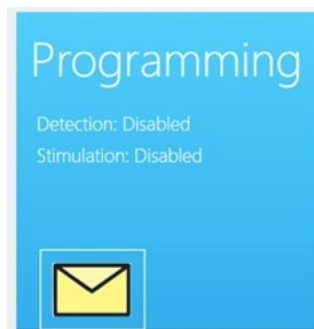
**Figure 57 Example message reporting successful sharing**

---

#### What Happens to a Shared Programming Set

Sharing a programming set using the foregoing method merely makes it available to the targeted user or programmer when connected to the PDMS. Shared programming sets are not automatically downloaded and saved locally to the programmer.

What happens is that the next time the targeted user or programmer is connected to the PDMS on the tablet, an envelope icon will appear on the **PROGRAMMING** tile of the **HOME** screen, as shown.



#### Available for Online Use, Not Offline

1. Select the **PROGRAMMING** tile to open the **PROGRAMMING SETS** screen, and touch in the **PROGRAMMING SETS** field to see the list of available program sets.
  - Programming sets are listed by date created, most recent first. (If someone else shared the programming set with you, the name of the programming set includes the username of the person who shared it or created it, in parentheses.) At the top of the list of programming sets, the name of the new programming set should be visible, with the envelope icon next to it.

2. When you select the new programming set, it is available for immediate programming to the target patient's neurostimulator. After reviewing pending programming changes and testing any changed stimulation settings, you can program the neurostimulator by selecting **PROGRAM RNS**.

This is a typical scenario for adjusting programming in a clinic follow-up visit. Note, however, whether or not you program any programming set while connected to the PDMS via the Internet, the programmer does *not* download and save the new programming set locally to the programmer for offline use. There is only one way to download a programming set to the programmer for offline use, described next.

### **Steps to Download a Programming Set to the Tablet for Offline Use**

To download a programming set and save it locally to the tablet for offline use, follow these steps:

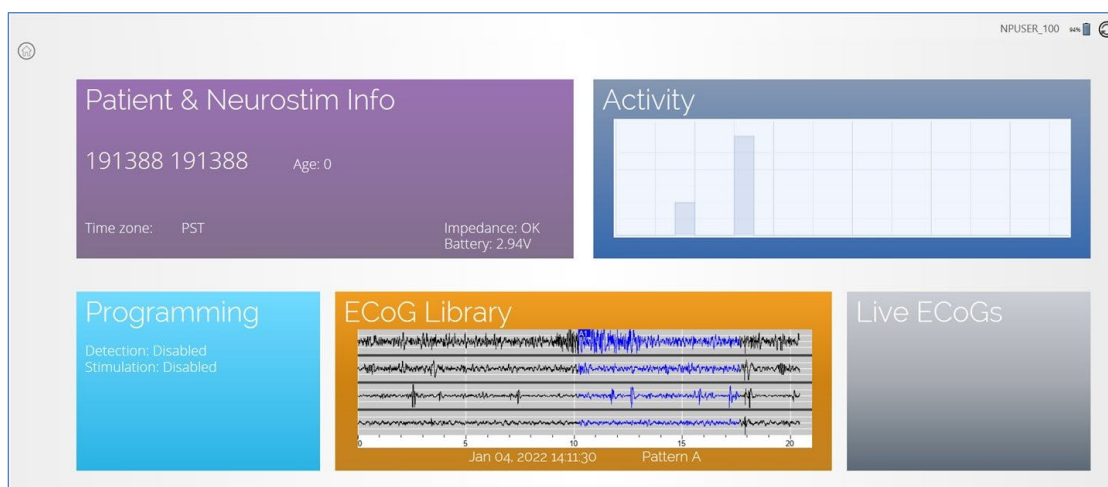
1. Using the tablet, navigate to the Start screen. (If you did not just log in to the tablet, use the Home button at upper left or Back button at upper right, if necessary, to reach the Start screen.) Reaching the Start screen ends any prior interactive programming session.



**Figure 58 Select Patient List in the Start screen**

2. Select the **PATIENT LIST** tile on the tablet Start screen and log in to the PDMS if necessary. This opens the **PATIENT LIST** on the PDMS.

3. Select the desired patient from the patient list. The **PATIENT HOME** screen opens. Note this is different than the tablet **HOME** screen (shown in **Figure 9** on page 22).

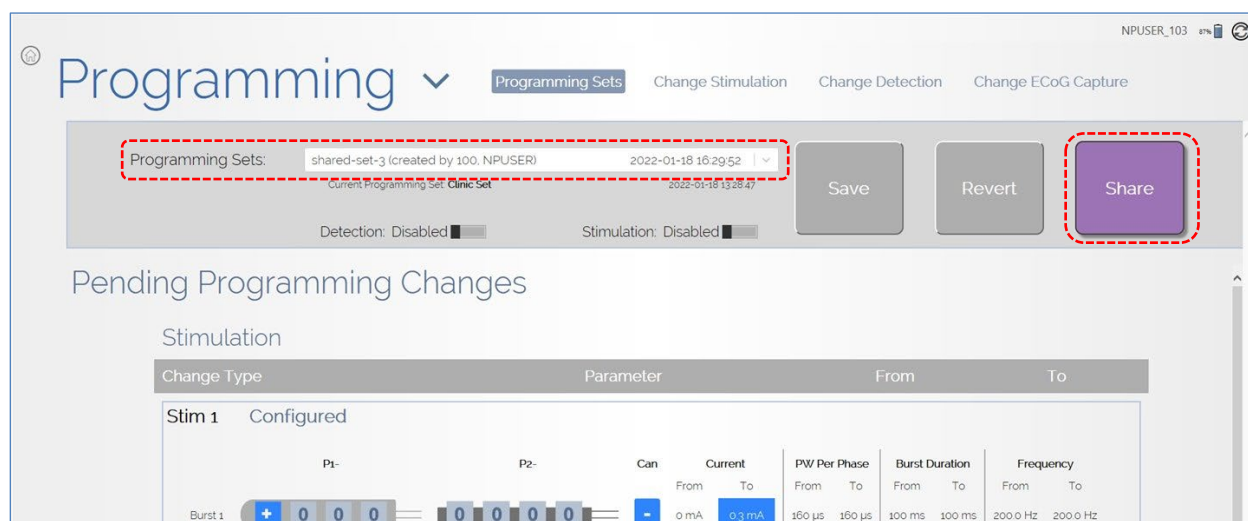



---

**Figure 59 Patient Home screen**


---

4. Select the **PROGRAMMING** tile. The **PROGRAMMING SETS** screen opens.
5. Touch in the **PROGRAMMING SETS** field to find and select the name of the programming set you want to download to the tablet. They are listed by date, most recent first. (If someone else created or shared the programming set with you, the name of the programming set includes the username of the person who created or shared it, in parentheses.) The **SHARE** button becomes active.




---

**Figure 60 Programming Sets screen**


---

6. Select the **SHARE** button. The **SHARE PROGRAMMING SET** dialog opens. On the tablet, it includes a checkbox named **DOWNLOAD TO THIS PROGRAMMER NOW** along with the other sharing options.

Share  
Programming Set

Name: stim-change-increase-amplitude  
Created: 1/3/2022 4:45:23 PM

Share with user:

Send to programmer:

Download to this programmer now:

---

**Figure 61 The SHARE PROGRAMMING SET dialog on the PDMS using the tablet**

---

7. Select the **DOWNLOAD TO THIS PROGRAMMER NOW** checkbox and then select the **SHARE** button.

A **PDMS TRANSFER** dialog appears briefly and closes when download is complete. The downloaded programming set has been saved locally to the programmer. It will be available on the programmer when there is no Internet connection. Using the programmer offline, you can select the downloaded programming set for programming after you interrogate the target patient's neurostimulator.

*Note: The downloaded programming set is not available if the programmer has Internet connection.*

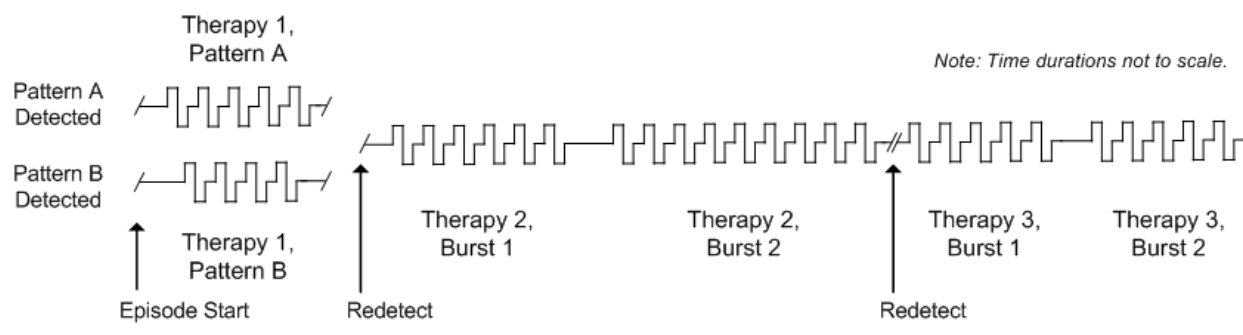
### OVERVIEW OF RESPONSIVE THERAPY

The RNS® Neurostimulator can deliver a therapy sequence of up to 5 individually configured therapies in response to detected activity. The neurostimulator resumes sensing after each therapy is delivered. If the activity is still detected, the next (sequential) therapy is delivered. If the activity is no longer detected, the remaining therapies are not delivered and the episode ends. Therapy sequence refreshes with the detection of each new episode.

The system enables you to configure behavior for the first therapy in therapy sequence in one of two ways:

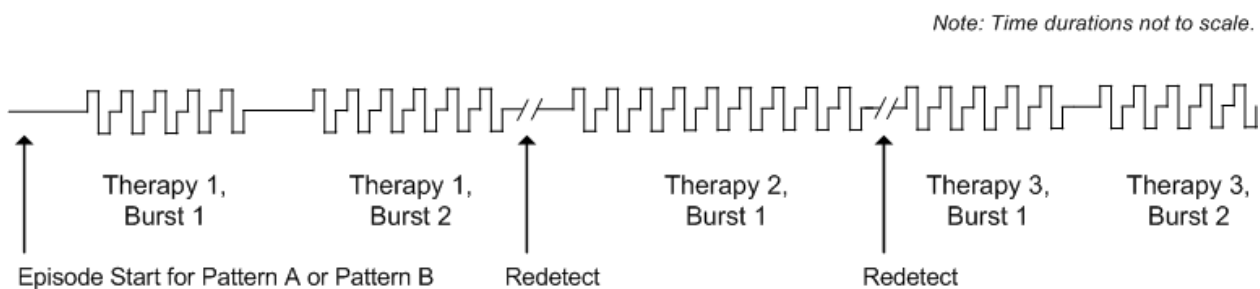
- You can select different bursts to be delivered in response to a specific event detector (Pattern A or Pattern B), as depicted in **Figure 62**; or
- You can select up to two bursts to be delivered in response to any event detector, as depicted in **Figure 63**.

All subsequent therapies deliver a maximum of 2 bursts and are independent of the event detector.



**Figure 62** A THERAPY SEQUENCE DELIVERED IN RESPONSE TO A SPECIFIC EVENT DETECTOR

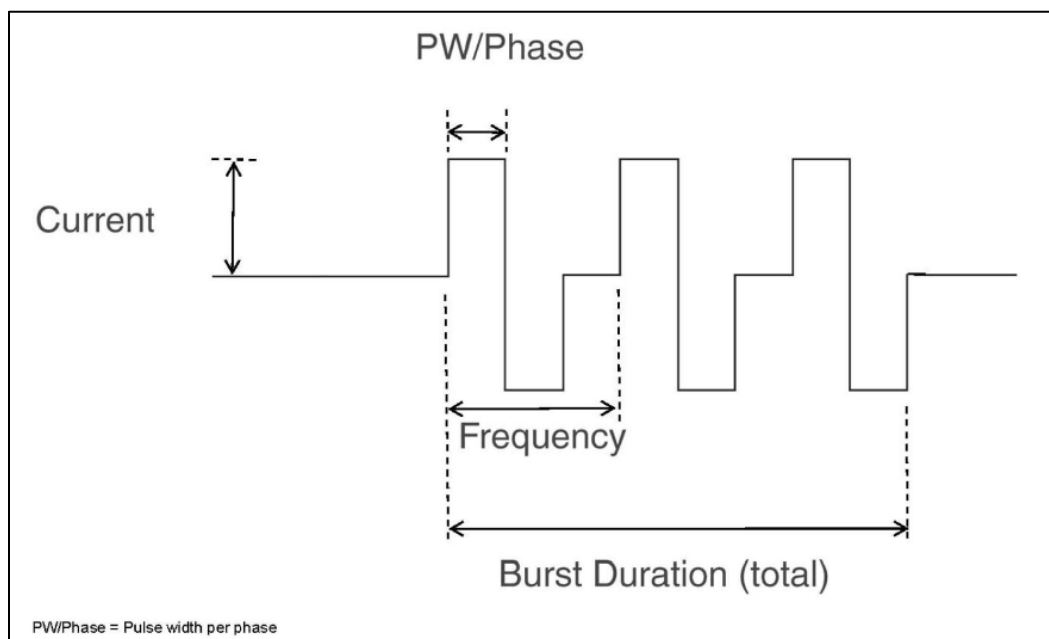
Therapy 1 is configured to deliver a single burst in response to a specific detector. In this example, Pattern A is detected at the episode start; Therapy Pattern A burst is delivered. If Pattern B is detected at the episode start, Therapy Pattern B burst is delivered. Subsequent therapies, Therapy 2 and Therapy 3, are configured to deliver 2 bursts each, no matter which pattern is subsequently detected.



**Figure 63** A THERAPY SEQUENCE DELIVERED IN RESPONSE TO ANY EVENT DETECTOR

Therapy 1 is configured to deliver Burst 1 and Burst 2 in response to any event detector. In subsequent therapies, Therapy 2 is configured to deliver Burst 1 only and Therapy 3 is configured to deliver Burst 1 and Burst 2.

The following figure identifies the parameters of a burst of stimulation therapy.



**Figure 64 Parameters of a single burst of stimulation**

## CONFIGURE RESPONSIVE THERAPY

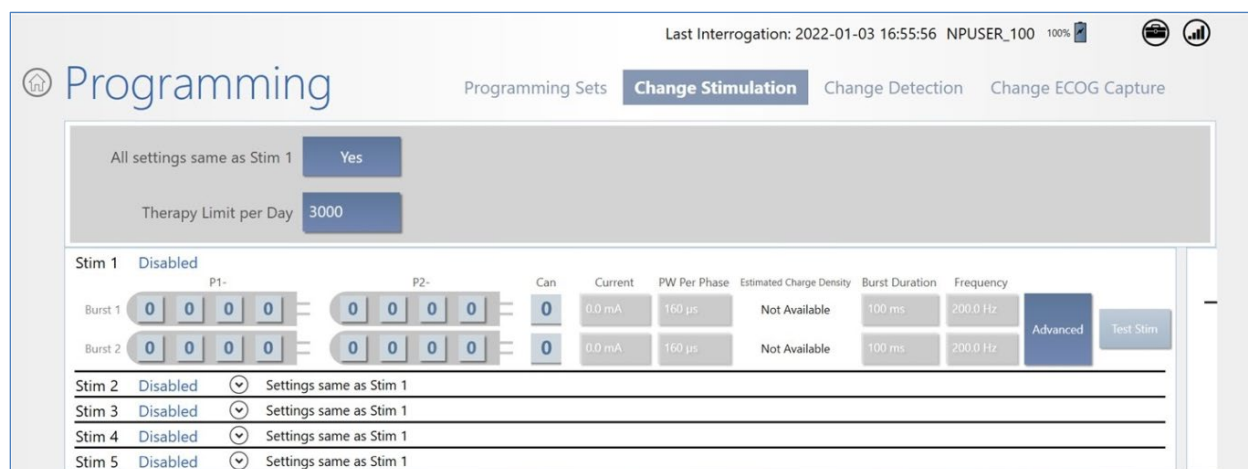
Detection must be enabled before responsive therapy can be enabled. Before programming responsive therapy, at least one detector must be defined in the detection settings. (If you select therapy specific to a detection pattern, at least one detector must be defined for each pattern.) To set up a therapy sequence, determine the number of therapies desired for delivery in response to an episode. Select each therapy and configure each burst, which is a collection of one to many biphasic pulses.

*Note: Changed settings are highlighted blue and new setting text is shown in larger font above the smaller old setting. Gray or plain items have not changed.*

*Note: It is recommended to review and perform detection analysis prior to enabling responsive therapy.*



1. Select **PROGRAMMING** from the **HOME** screen.
2. Select **CHANGE STIMULATION** at upper center of the **PROGRAMMING** screen. The **CHANGE STIMULATION** screen opens. (Swipe left to see the right side.)



**Figure 65** Change Stimulation screen, left side. Swipe left to see right side.

The screen has rows **STIM 1** through **STIM 5** to program up to five stimulation therapies. Each therapy is either configured or disabled. When one of the five therapies is disabled, all successive therapies are disabled also—you cannot skip a therapy. Recall that detection must be enabled before therapy can be enabled.

3. **Select Stimulation Pathway:** The stimulation pathway consists of the electrodes on each lead across which stimulation is delivered, as configured by the user. For each desired stimulation therapy and burst, starting with **STIM 1 BURST 1**, select the electrodes on each lead across which to deliver therapy, by making at least one electrode positive [+] and another negative [-]. Note that the neurostimulator can is an optional electrode.

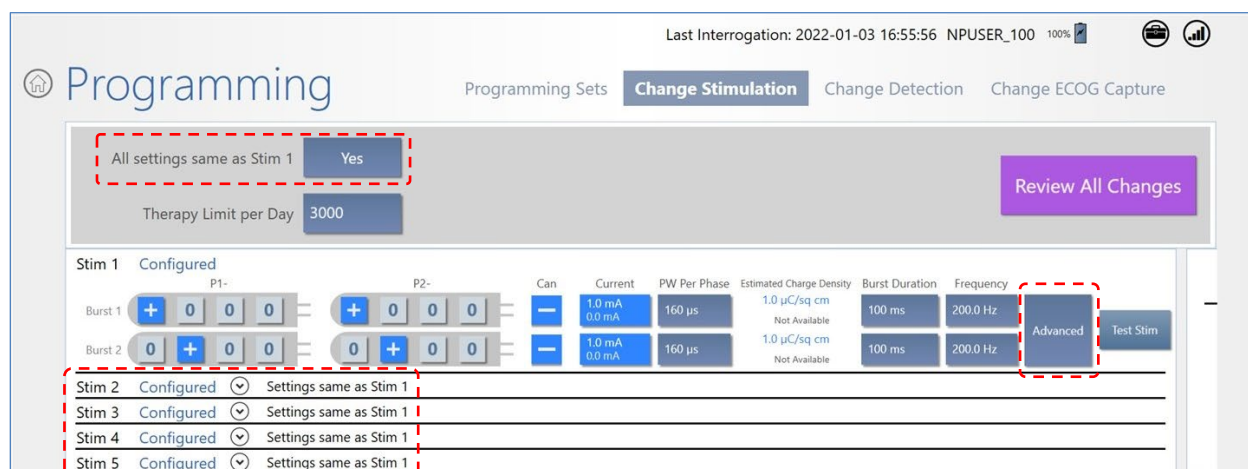
In general, stimulation should be delivered to the leads and electrodes from which electrographic patterns of interest are observed. For example, if electrographic activity of

interest is observed on all channels, then the stimulation pathway should be configured to stimulate across all electrodes. However, if electrographic activity of interest is observed on only 2 channels, then the stimulation pathway should be configured such that current is delivered through only those electrodes with electrographic activity of interest.

4. Select the level of **CURRENT** to be delivered during pulses.
5. Select the **PW PER PHASE**, which is the pulse width or duration (in  $\mu\text{s}$ ) of each phase of the biphasic current pulse.

*Note: The **ESTIMATED CHARGE DENSITY** reported on screen is a function of **CURRENT**, **PW PER PHASE**, and the number of electrodes in the stimulation pathway. The tablet limits the available choices for **CURRENT** and **PW PER PHASE** to those which yield an **ESTIMATED CHARGE DENSITY** less than  $25 \mu\text{C}/\text{sq cm}$ .*

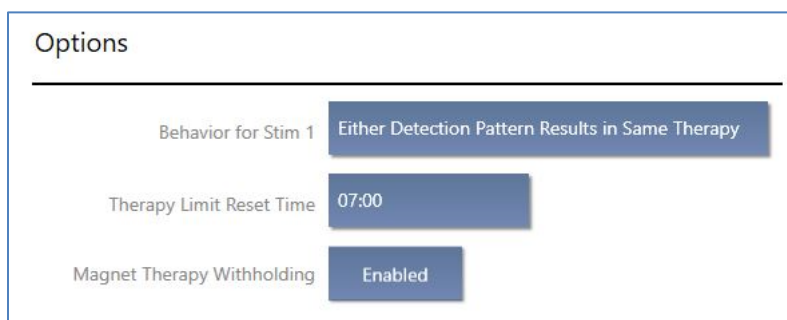
6. Select the **BURST DURATION**, from 10 ms to 5000 ms.
7. Select the **FREQUENCY** of the biphasic current pulses, from 1 Hz to 333.3 Hz. Increasing frequency decreases the time between each biphasic pulse of current, and vice versa.
8. To apply the same settings to all five stimulation therapies, make sure the button next to **ALL SETTINGS SAME AS STIM 1** is toggled to **YES**, near top left of the screen. To make different settings for Stim 2 or higher, select the **YES** button to toggle it to **NO** and then make changes.



**Figure 66 Stim 1 settings copied to all therapies**

- Note that the **REVIEW ALL CHANGES** button appears when you begin to edit settings.
9. If desired, select **THERAPY LIMIT PER DAY** at upper left to adjust the maximum number of episodes the neurostimulator will treat per day.

10. If desired, swipe left to access the **OPTIONS** area on the right side of the **CHANGE STIMULATION** screen to find the following options:




---

**Figure 67 Options on the right side of the Stimulation settings screen**

---

- BEHAVIOR FOR STIM 1:** The default is **EITHER DETECTION PATTERN RESULTS IN SAME THERAPY**. Select the field to select the alternate **DETECTION PATTERN SPECIFIC THERAPY**, to apply only Therapy 1 in response to detection of one specific pattern you have programmed.
  - THERAPY LIMIT RESET TIME:** Select the time of day (in 24-hour time) when the daily therapy limit count resets to zero.
  - MAGNET THERAPY WITHHOLDING:** The default is **ENABLED**, which enables the magnet to withhold therapy as long as the magnet is over the neurostimulator. Once the magnet is removed, therapy can resume. To disable this functionality, select the field to toggle to **DISABLED**.
- Swipe right to return to the left side of the **CHANGE STIMULATION** screen.
- If desired, select **ADVANCED** at far right of the row to adjust the **Optional Advanced Settings** described on page **82** and following.
11. Skip to **Test Stimulation Before Enabling** on page **84** if you do not want to use the advanced settings.

**Optional Advanced Settings**

If desired, select **ADVANCED** at far right of the row to open the **ADVANCED SETTINGS** screen for the selected therapy (**STIM** row). By default, all advanced settings are disabled.

Stim1 Advanced Settings

Adapt Channel	Unused		
Adapt Min Amplitude	10.2 %		
<b>Burst 1</b>		<b>Burst 2</b>	
Adaptation	Off	Adaptation	Off
Therapy Frequency Multiplier	16.00	Therapy Frequency Multiplier	16.00
Max Therapy Frequency	166.7 Hz	Max Therapy Frequency	166.7 Hz
Min Therapy Frequency	10.0 Hz	Min Therapy Frequency	10.0 Hz
Default Therapy Frequency	50.0 Hz	Default Therapy Frequency	50.0 Hz
<b>Synch Channel</b>		<b>Burst 2</b>	
Synch Min Amplitude	10.2 %	Burst 2 is always delivered Asynchronously	
Time Out	2.0 secs		
Synchronization	Off		
Delay	0 ms		
Synch Slope	Up		
Post-episode Interval	4.0 secs		
Done			

**Figure 68 Stim 1 Advanced Settings**

The **ADVANCED SETTINGS** screen has upper, lower and bottom portions that let you select the following:

**Upper portion—Adaptive Therapy:** Adapts the frequency and the minimum amplitude of the stimulation therapy as a percentage of the detected signal amplitude over a chosen channel, for one or both bursts. The available options are:

Stim1 Advanced Settings

Adapt Channel	Unused		
Adapt Min Amplitude	10.2 %		
<b>Burst 1</b>		<b>Burst 2</b>	
Adaptation	Off	Adaptation	Off
Therapy Frequency Multiplier	16.00	Therapy Frequency Multiplier	16.00
Max Therapy Frequency	166.7 Hz	Max Therapy Frequency	166.7 Hz
Min Therapy Frequency	10.0 Hz	Min Therapy Frequency	10.0 Hz
Default Therapy Frequency	50.0 Hz	Default Therapy Frequency	50.0 Hz

**Figure 69 Adaptive therapy settings—upper portion of Advanced Settings dialog**

- **ADAPT CHANNEL:** Select one of four channels over which to enable adaptive therapy. By default, this is **UNUSED**, which means adaptive therapy is disabled.
- **ADAPT MIN AMPLITUDE:** Select a percentage of the detected signal amplitude to be used as the minimum therapy amplitude.

Then for **BURST 1** and/or **BURST 2**, select settings for the following:

- **ADAPTATION:** Turn **ON** or **OFF** adaptive therapy for this burst.
- **THERAPY FREQUENCY MULTIPLIER:** A greater multiplier increases frequency of the burst.
- **MAX THERAPY FREQUENCY:** Sets maximum frequency for this burst.
- **MIN THERAPY FREQUENCY:** Sets minimum frequency for this burst.
- **DEFAULT THERAPY FREQUENCY:** Sets default frequency for this burst.

**Illustration:** If **ADAPT MIN AMPLITUDE** = 100% and the detected signal frequency = 20 Hz (50 ms period), the stimulation frequency is delivered at 20 Hz (50 ms p-p interval). If **ADAPT MIN AMPLITUDE** = 50% and the sensed signal frequency = 20 Hz (50 ms period), the stimulation frequency is delivered at 40 Hz (25 ms p-p interval).

If the neurostimulator cannot detect a stable frequency in the ECoG signal, or if the calculated stimulation frequency is not between the **MAX THERAPY FREQUENCY** and **MIN THERAPY FREQUENCY**, then the burst is delivered at the **DEFAULT THERAPY FREQUENCY**.

**Lower portion—Synchronized Therapy:** For **BURST 1** only, synchronize delivery of therapy into a specific part of the detected ECoG waveform over a chosen channel. The available options are:

<b>Synch Channel</b>	Unused	
Synch Min Amplitude	10.2 %	
Time Out	2.0 secs	
<b>Burst 1</b>		<b>Burst 2</b>
Synchronization	Off	Burst 2 is always delivered Asynchronously
Delay	0 ms	
Synch Slope	Up	

**Figure 70 Synchronized therapy settings—lower portion of Advanced Settings dialog**

- **SYNCH CHANNEL:** Select one of four channels over which to deliver synchronized therapy.
- **SYNCH MIN AMPLITUDE:** Select a percentage of the detected signal amplitude to be used as the minimum amplitude for synchronized therapy.

Then for **BURST 1** and/or **BURST 2**, select settings for the following:

- **SYNCHRONIZATION:** Turn **ON** or **OFF** synchronized therapy for **BURST 1**. (Burst 2 is always delivered asynchronously.)

- **DELAY:** Set the delay (in ms) for delivery of **BURST 1** therapy after detection of the target ECoG waveform.
- **SYNCH SLOPE:** Select **UP** or **DOWN**.

*Note: If the neurostimulator is unable to synchronize therapy into a detected waveform, it reverts to asynchronous therapy delivery after 2 seconds.*

**Bottom portion—Post-Episode Interval:** Select the **POST-EPISEODE INTERVAL**, from **OFF** (default) to **24 HRS**, to specify the time the neurostimulator waits after the end of an episode before treating a new episode. During the post-episode interval, monitoring continues but the system will not deliver therapy for a new episode.

**Figure 71 Post-episode interval settings—bottom portion of Advanced Settings dialog**

**Save Advanced Settings:** Select **DONE** to save the new advanced settings and return to the **CHANGE STIMULATION** screen.

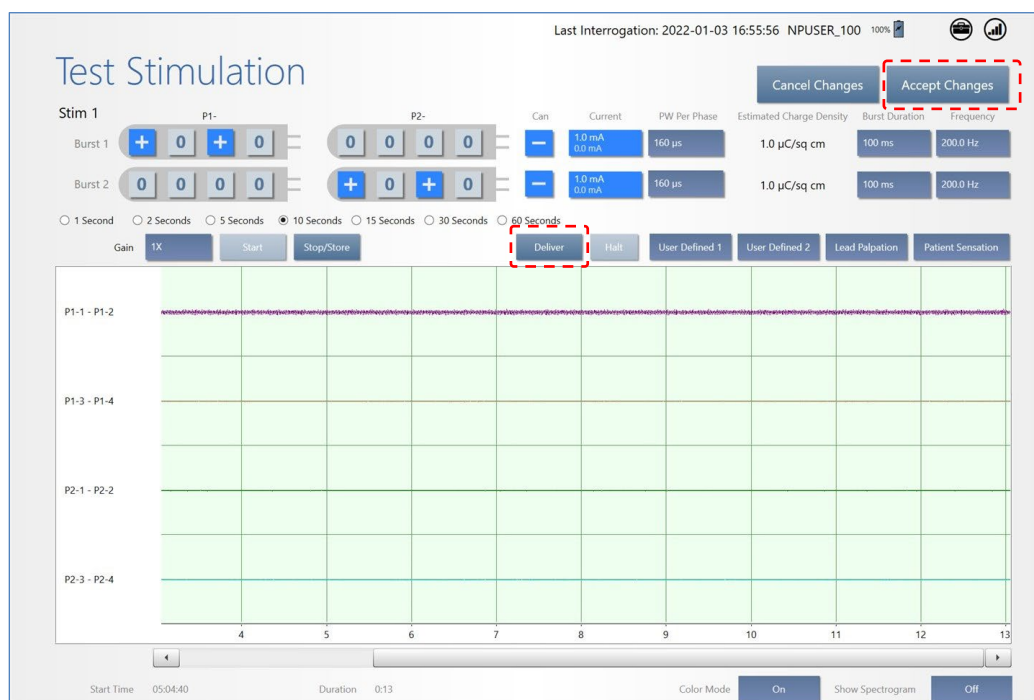
### **Test Stimulation Before Enabling**

Before enabling responsive therapy, it is important to test stimulation to make sure it is well tolerated by the patient and there are no undesired changes in the ECoG, such as afterdischarges.

*Note: The system cannot test stimulation during a detected episode or during therapy delivery. To test stimulation, either wait for the episode or therapy to complete, or disable detection and therapy.*

1. While holding the wand over the neurostimulator, select **TEST STIM** on the far right of the row to open the **TEST STIMULATION** screen and test the new stimulation settings. Note that the **TEST** button is not available if adaptive therapy is on (see **Optional Advanced Settings** above).

- An ECoG is running when the screen opens. Select **DELIVER** to deliver the test burst. Select **STOP/STORE** when desired to stop recording.



**Figure 72 Test Stimulation screen**

- You can adjust settings and retest while this screen is open. To exit test stimulation, select **ACCEPT CHANGES** or **CANCEL CHANGES** at upper right.
  - Stimulation may evoke visual, olfactory, auditory, taste, sensory or motor responses.
  - Test stimulations should be delivered to each electrode individually (electrode to neurostimulator) to determine whether there are acute side effects from stimulation.
  - Habituation to side effects resulting from stimulation has been observed; however it is not advised to program settings that cause patient discomfort.
  - Avoid stimulation settings that cause an electrographic afterdischarge.

**Caution: Afterdischarge Activity**

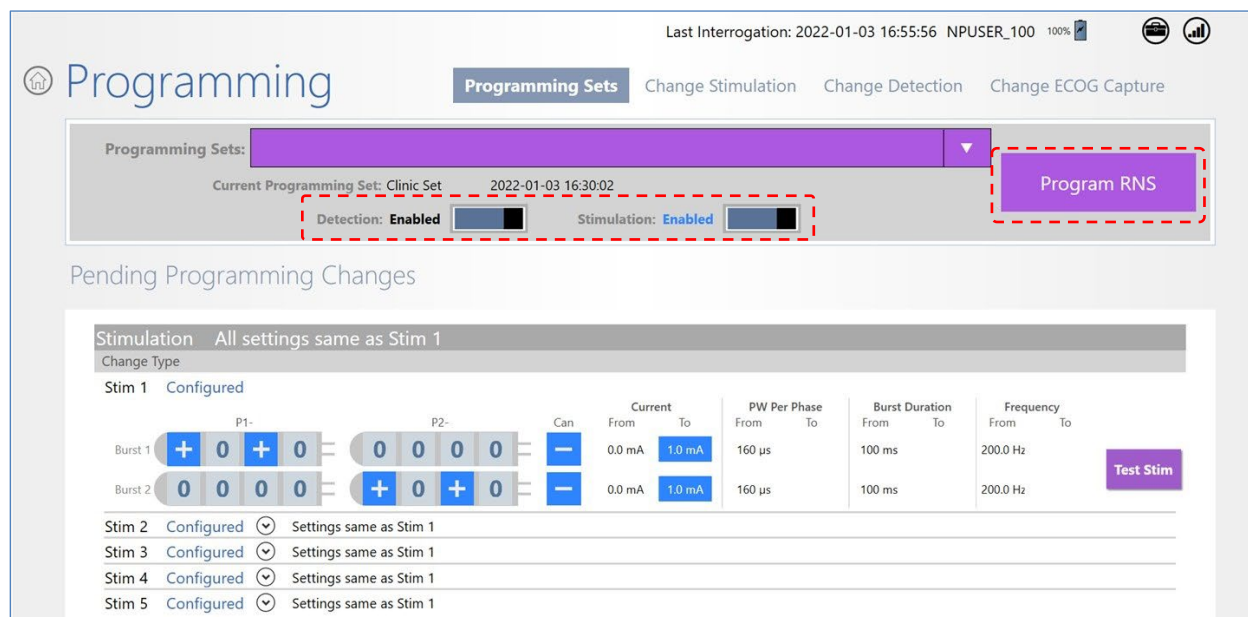
If evidence of afterdischarge activity resulting from stimulation is seen either on stored ECoGs or during test stimulation delivery, stimulation parameters should be adjusted to prevent such occurrence.

**Enable Therapy: Program RNS**

The new settings are not sent to the neurostimulator until you complete these steps.

- Select **REVIEW ALL CHANGES** at upper right. All **PENDING PROGRAMMING CHANGES** appear on the **PROGRAMMING** screen for your review before programming. Scroll down if necessary to see all the changes. Note that **TEST STIM** is available on the **PROGRAMMING SETS** screen;

- ensure that any changes to stimulation settings have been tested prior to programming stimulation changes.
- To activate the configured therapy, make sure **STIMULATION** is set to **ENABLED** at upper center. (**DETECTION** also must be **ENABLED** to deliver therapy.)



**Figure 73 Pending Programming Changes. Blue items have changed.**

- If you are satisfied with the new or changed settings, place the wand within approximately 1 inch of the neurostimulator and select **PROGRAM RNS**. The **PROGRAMMING NEUROSTIMULATOR** dialog shows programming progress until complete.

If you are not satisfied with the pending changes, select the desired button to **CHANGE DETECTION**, **CHANGE STIMULATION** or **CHANGE ECOG CAPTURE**, and after making changes, select **REVIEW ALL CHANGES** and then **PROGRAM RNS**.

### **Recommended Initial Responsive Therapy Settings**

Responsive stimulation therapy should be enabled once the physician has determined the electrographic activity of interest is being detected.

- Program **BURST 1** for electrodes on one lead and **BURST 2** for electrodes on the other lead.
- FREQUENCY** = 200 Hz (default)
- BURST DURATION** = 100 ms (default)
- PW PER PHASE** = 160 µs (default)
- CURRENT** = Adjust current to achieve Charge Density of 0.5 µC/sq cm.
  - The RNS Tablet estimates charge density based on current, PW per phase, and the number of electrodes in the stimulation pathway. After selecting PW per phase and stimulation pathway, the physician should adjust current to achieve targeted charge density. For example, for a stimulation pathway with all electrodes on one lead

programmed cathodal and the Can programmed anodal, using the default PW per phase value of 160  $\mu\text{s}$  and setting current to 1.0 mA results in charge density of 0.5  $\mu\text{C}/\text{sq cm}$ .

- Apply the same settings to all five stimulation therapies: select the **YES** button next to **ALL SETTINGS SAME AS STIM 1**, near top center of the screen.

In general, stimulation should be delivered to the leads and electrodes from which electrographic patterns of interest are observed. For example, if electrographic activity of interest is observed on all channels, then the stimulation pathway should be configured to stimulate across all electrodes. However, if electrographic activity of interest is observed on only 2 channels, then the stimulation pathway should be configured such that current is delivered through only those electrodes with electrographic activity of interest.

### **Recommended Therapy Modifications After Observing Clinical Response**

Once the neurostimulator is programmed to provide responsive stimulation, the patient should be seen at approximately 3-month intervals to determine whether detection and/or responsive therapy settings should be modified. At each patient visit, the physician reviews ECoGs that are stored on the PDMS or programmer. Detection settings should promptly detect ECoG activity and not detect on baseline activity.

Based on the clinical response, the physician may choose to modify stimulation. After selecting PW per phase and stimulation pathway, current can be used to adjust charge density. It is recommended that the charge density be increased in 0.5  $\mu\text{C}/\text{sq cm}$  increments. Longer pulse widths or fewer electrodes result in larger charge density changes for each mA current change. It is strongly recommended that the new settings be tested (see **Test Stimulation Before Enabling** on page 84) to ensure that it is well tolerated by the patient and there are no undesired changes in the ECoG such as afterdischarges.

- Review data such as lead impedance, battery voltage, number of detections and stimulations, and stored ECoGs.
- Adjust stimulation settings if the patient reports an acute worsening or increase in clinical seizures that is not typical.
- Consider making minor adjustments if the patient reports only a mild or no improvement in clinical seizures.
- Allow sufficient time between stimulation adjustments to assess the patient's clinical seizure response.

In the RNS<sup>®</sup> System Pivotal study very few subjects used any of the additional responsive stimulation therapy options (see **Table 1**). These were: pattern specific therapy (each detector triggers a different stimulation setting); adaptive therapy (the stimulation frequency adjusts with the ECoG frequency); synchronized stimulation (stimulation is delivered into a specific part of the ECoG waveform); and post episode interval (responsive therapies are disabled for a specified period of time after detecting the end of the episode). **Table 1** provides the number and percentage of subjects who were treated with any of the additional stimulation therapy options.

**Table 1: Additional responsive stimulation therapy options**

	<b>Number and (%) of Subjects Programmed</b>
Pattern Specific Therapy	29 (15%)
Adaptive Therapy	4 (2%)
Synchronized Stimulation	3 (2%)
Post-Episode Interval	4 (2%)

## **EXPORT AND IMPORT DEVICE SETTINGS FOR NEUROSTIMULATOR REPLACEMENT**

The tablet supports the transfer of all device settings from an old to a new neurostimulator as part of a neurostimulator replacement procedure. With the **EXPORT DEVICE SETTINGS** and **IMPORT DEVICE** functions, you can transfer all current neurostimulator settings (recording montage, detection settings, stimulation settings, etc.) to the new neurostimulator.

Export and import are done directly through the tablet without using the PDMS—exported settings are kept locally on the tablet—so no Internet connection is required. This also means that the programmer to which the settings have been exported must be physically present with the new neurostimulator to import settings to the new neurostimulator. This is not usually an issue because export and import are done on the same day: before, during or after the procedure to replace the neurostimulator.

### **Transfer Compatibility**

You can transfer settings from an RNS-300M to an RNS-300M or to an RNS-320, and you can transfer settings between RNS-320 devices.

*Note: **SCHEDULED IMPEDANCE** is a new feature in the RNS-320. It allows you to select which electrodes to test for impedance. Since the feature is not present in the RNS-300M, you must select the electrodes to test (and then program) on the new RNS-320 before scheduled impedance works. Its settings are created as part of the recording montage—see **Create the Recording Montage** on page 38 for instructions.*

### **Export Neurostimulator Settings**

1. Interrogate the old neurostimulator, the one **from** which you will transfer settings.
2. Select the **UTILITIES** (toolbox) icon at upper right of the screen. The **UTILITIES** dialog opens.



---

**Figure 74 Utilities dialog**

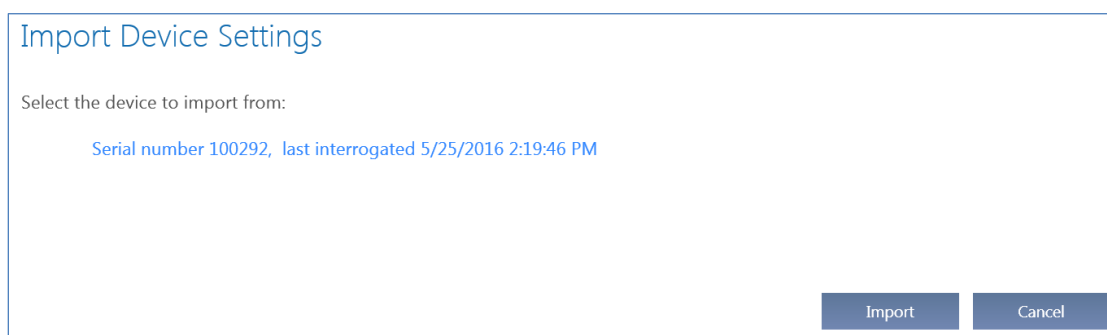
---

3. While holding the wand over the neurostimulator, select **EXPORT DEVICE SETTINGS**. You are done. All current neurostimulator settings are stored on the tablet ready for import.

*Note: The tablet retains only the last device settings exported to it—from any neurostimulator. Every export operation from any neurostimulator overwrites these device settings, if any. Successfully importing and programming the settings from the tablet to a new neurostimulator also deletes these device settings from the tablet.*

### **Import Neurostimulator Settings**

1. Interrogate the new neurostimulator, the one **to** which you will transfer settings.
2. Select the **UTILITIES** (toolbox) icon at upper right. The **UTILITIES** dialog opens (see figure above).
3. Select **IMPORT DEVICE**. The **IMPORT DEVICE SETTINGS** dialog appears. It shows the device settings available for import by device serial number and the date and time of last interrogation before the settings were exported to the tablet. It also notifies you if the tablet has no settings that came from a compatible neurostimulator (for example, if you exported from an RNS-320 for use on an RNS-300M).



---

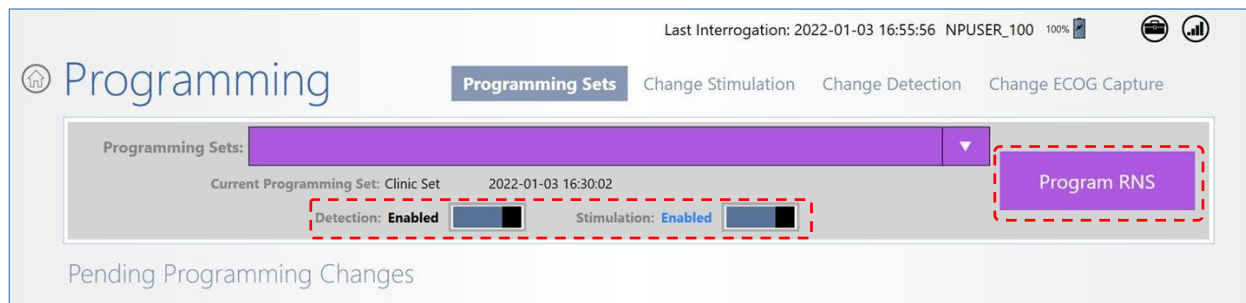
**Figure 75 Import Device Settings dialog**

---

*Note: Device settings can be imported only once because they are deleted from the tablet once you successfully import and select **PROGRAM RNS** from the **PROGRAMMING** screen, as described below.*

- Select the device settings—the selected settings will be highlighted—and then select **IMPORT**. The dialog notifies you that it is importing device settings.

When complete, the tablet **PROGRAMMING** screen opens. The active (purple) **PROGRAM RNS** button indicates pending settings are not yet programmed.

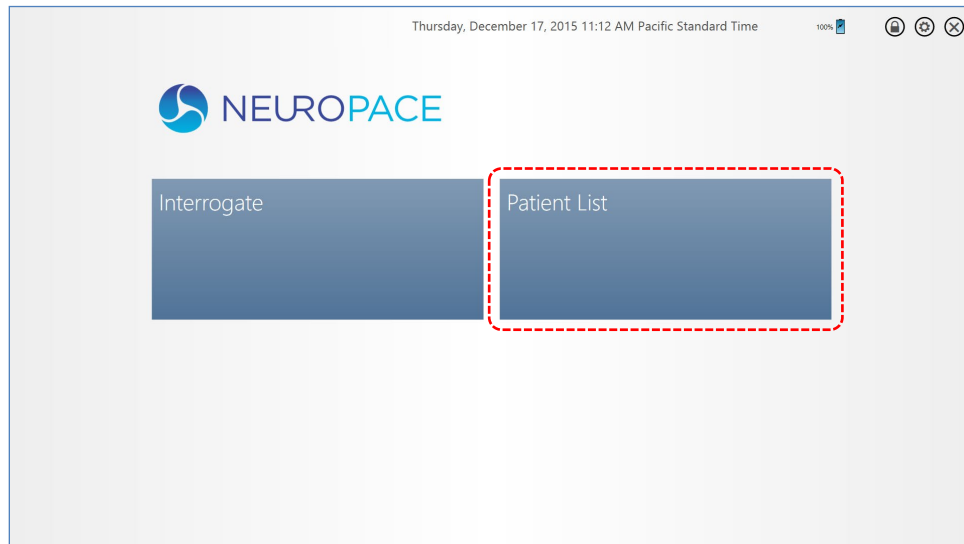


- If you want to enable detection and stimulation at this time, make sure **DETECTION** and **STIMULATION** are set to **ENABLED** at upper center.
- Place the wand within approximately 1 inch of the neurostimulator and select **PROGRAM RNS**. The **PROGRAMMING NEUROSTIMULATOR** dialog shows programming progress until complete. The imported settings are deleted from the tablet when programming is complete. If you do not complete this step, the settings will remain available on the tablet.

*Note: After implanting a replacement neurostimulator, monitor the detection behavior. It may be necessary to adjust the detection settings to ensure desired performance. If a bandpass detection tool (**RHYTHMIC ACTIVITY** or **SPIKE ACTIVITY**) is enabled and the settings need to be adjusted, begin by modifying the amplitude settings. See **Recommended Therapy Modifications After Observing Clinical Response** on page 86.*

## PATIENT LIST ON TABLET AND THE PDMS ON A PERSONAL COMPUTER

The **PATIENT LIST** on the tablet and the PDMS on a personal computer give access to stored data for a selected patient. Their appearance and behavior is the same. The **PATIENT LIST** tile on the tablet Start screen works only when the tablet is connected to the PDMS (through the Internet).



---

**Figure 76 Tablet Start screen**

---

Whether you select **PATIENT LIST** on the tablet Start screen or log in to the PDMS on a personal computer, the information is displayed in a similar way, and on the same-named screens, as when you start an interactive programming session by interrogating the neurostimulator. When you select **PATIENT LIST** on the tablet, the difference is that you are not interacting with a neurostimulator; you are only accessing stored neurostimulator information like detection and stimulation settings, and stored activity reports.

## PDMS ACCESS ON A PERSONAL COMPUTER

Access to the secure PDMS database on a personal computer requires a username and password. If NeuroPace has not already provided these to you, contact NeuroPace to obtain a username and temporary password. You are responsible for maintaining the confidentiality of your username and password.

*Note: The PDMS requires you to change your password after logging in for the first time.*

1. Using any computer with Internet access, open a web browser and select the PDMS link on [www.neuropace.com](http://www.neuropace.com)
2. Enter your **USERNAME** and **PASSWORD**.
3. Click **LOG IN**.

**Figure 77 PDMS Login on a personal computer**

*Note: If you have forgotten your password select **RESET YOUR PASSWORD OR ACCESS YOUR PASSWORD HINT**. The password hint you entered will be sent to the email address listed in your profile.*

The **PATIENT LIST** opens immediately when you log in to the PDMS using a web browser, just as when you select the **PATIENT LIST** tile on the tablet. Follow the continuing instructions below to access PDMS functions, which apply both on the tablet and on a personal computer.

## PDMS PROFILE AND SETTINGS

The toolbox icon at upper right of every screen gives access to view and change your:

- Profile
- Password
- Time Zone



1. To reach the **PATIENT LIST** on the tablet, select **PATIENT LIST** from the Start screen. The **PATIENT LIST** screen opens. When you log in to the PDMS via a web browser, it opens directly on the **PATIENT LIST** screen.



Figure 78 Patient List screen

2. Select a patient from the **PATIENT LIST**. The **PATIENT HOME** screen opens.

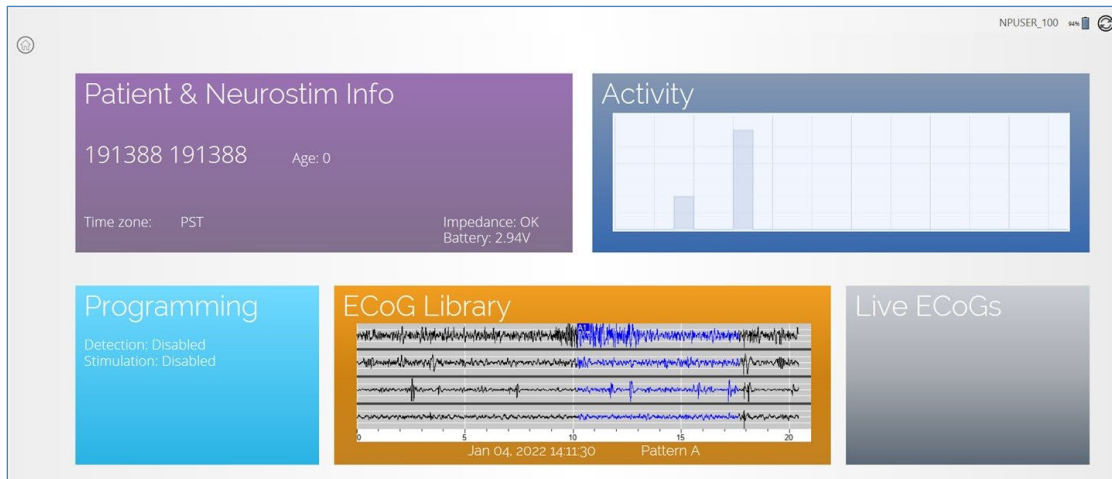


Figure 79 Patient Home screen

3. Select a tile to view its associated data for this patient.

- **PATIENT & NEUROSTIM INFO**
- **PROGRAMMING**
- **ACTIVITY**
- **ECoG LIBRARY**
- **LIVE ECoGs**

You can switch between patient views or return to the **PATIENT HOME** screen by touching the screen title at upper left (or the down-arrow next to it).



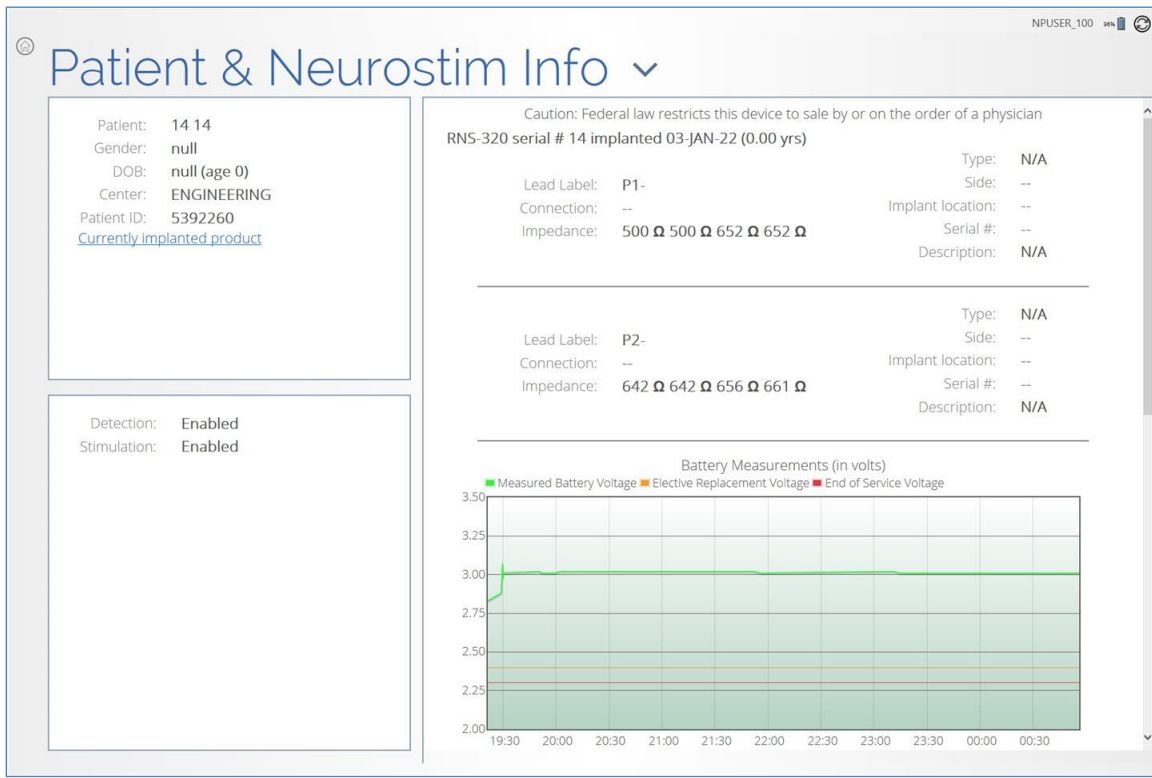
---

**Figure 80 Select to switch between patient views**

---

The following sections provide details about each view.

## PATIENT &amp; NEUROSTIM INFO




---

**Figure 81 Patient & Neurostim Info screen**


---

This screen provides:

- At upper left, patient information. Select **CURRENTLY IMPLANTED PRODUCT** to see details about the implanted products.
- At lower left, whether **DETECTION** and **STIMULATION** are **ENABLED** or **DISABLED**.
- At upper right, information about the neurostimulator (serial number, implant date), leads, and electrodes.
- At lower right (swipe up or scroll to see), graphs of battery and impedance measurements over time.

## PROGRAMMING

- The **PROGRAMMING SETS** screen opens first and gives access to screens to **CHANGE STIMULATION**, **CHANGE DETECTION** and **CHANGE ECoG CAPTURE**. Apart from dimensions and non-clinical details, these screens are the same using the PDMS on a tablet (via the **PATIENT LIST** tile) and on a web browser.

*Note: Programming sets created on the PDMS must be saved and shared with users or programmers to be available for programming using a tablet. For instructions, see **Share and/or Download a Programming Set** on page 71.*

- **CHANGE DETECTION** screen: While accessing the PDMS outside an interactive programming session, the **CHANGE DETECTION** screen looks the same as seen in **Figure 40** (on page 54). It behaves the same (tablet vs. PDMS web browser) in that you can define, modify, and save detection settings for the patient you selected in the patient list. For instructions to use this screen, see **Configure Detection: Define and Modify Detection Settings** on page 49, starting with **Phase 2: Define Detection Settings** on page 53.
- **CHANGE STIMULATION** screen: This screen behaves the same (tablet vs. PDMS web browser) in that you can define, modify, and save stimulations settings for the patient you selected in the patient list. See **Configure Responsive Therapy** on page 78.
- **CHANGE ECoG CAPTURE** screen: This screen behaves the same (tablet vs. PDMS web browser) in that you can define, modify, and save ECoG capture settings for the patient you selected in the patient list. See **Set up ECoG Capture** on page 43.

### Download for Offline Use

After saving a programming set, you can download the programming set to a target programmer, where it is saved locally. This makes it available to program the neurostimulator while the programmer is offline, as is required, for example, if an operating room lacks network connectivity. See **Steps to Download a Programming Set to the Tablet for Offline Use** on page 74.

## ACTIVITY

The **ACTIVITY** screen looks and behaves as shown and explained under **Activity Screen** starting on page 28.

## ECoG LIBRARY

The **ECoG LIBRARY** screen looks and behaves as shown and explained under **ECoG Library Screen** starting on page 35.

## LIVE ECoGs

The **Live ECoGs** tile is inactive through the **PATIENT LIST** on the tablet and the PDMS via the Internet. It can be active only on the tablet, provided it is in communication with a neurostimulator, as described under **Live ECoGs Screen** starting on page 37.

## PATIENT FOLLOW-UP ACTIVITIES

The following activities are recommended at a follow-up visit:

- Interrogate the RNS<sup>®</sup> Neurostimulator. See **Interrogate the RNS<sup>®</sup> Neurostimulator** on page **19**.
- Review measured battery voltage and electrode impedance on the **Neurostim Info Screen**—see page **24**. These are measured routinely during interrogation.

*Note: Battery voltage and electrode impedance are measured during interrogation. If these two values were not measured (e.g., because therapy was being delivered), measure them manually using the applicable **MEASURE** button on the **NEUROSTIM INFO** screen.*

- Review stored ECoGs on the **ECoG Library Screen**—see page **35**—to review and consider adjustments to:
  - ECoG capture settings—see **Set up ECoG Capture** on page **43**
  - Detection settings—see **Configure Detection: Define and Modify Detection Settings** on page **49**
  - Responsive therapy settings—see **Configure Responsive Therapy** on page **78**

*Note: You must be connected to the PDMS via the Internet to review stored ECoGs, neurostimulator activity and all other neurostimulator information in a patient's history. See **Connect and Login Overview** on page **10**.*

- View live ECoGs—see **Live ECoGs Screen** on page **37**.
- If you adjust detection settings, review the simulated detection on an ensemble of stored ECoGs before programming. See **Phase 2: Define Detection Settings** on page **53** or **Phase 3: Customize Detection** on page **58**.
- If you adjust stimulation settings, test the patient's tolerance for the new settings before programming. See **Test Stimulation Before Enabling** on page **84**.
- If you change any settings, remember to program the new settings into the neurostimulator, as described in each applicable section.

**Caution: Afterdischarge Activity**

If evidence of afterdischarge activity resulting from stimulation is seen either on stored ECoGs or during test stimulation delivery, stimulation parameters should be adjusted to prevent such occurrence.

## TROUBLESHOOTING

*Note: This section addresses only problems specific to the RNS® Tablet. For troubleshooting information regarding other components of the RNS® System, see the RNS® System manual. For troubleshooting information regarding the NeuroPace® Remote Monitor, see the NeuroPace® Remote Monitor Manual.*

If the information in this section does not resolve the problem, contact NeuroPace for further assistance (see **Contacting NeuroPace** on page 5).

### **Network Connectivity Problems**

For an overview and step-by-step instructions to establish full network connectivity with the tablet, see **Connect and Login Overview** on page 10 and following.

If you are already logged in to the tablet and have lost network connectivity, first log off to return to the login screen: return to the Start screen (see **Figure 5 Start screen** on page 17) and touch the circle-X (exit) button at upper right, and then select **EXIT** on the **PROGRAMMER EXIT** dialog. Follow the instructions under **Connect to the Internet for PDMS Access** on page 11 to establish a connection.

- If a PDMS screen appears to get “stuck” or is not responding, select the **REFRESH** button at upper right.

*Note: If you attempt to connect to a Wi-Fi network that requires you to go to an Internet website to log in, as in some hotels and coffee shops, you will not be able to log in because the tablet does not have an Internet browser program. As a medical device, its Internet connectivity is restricted to the PDMS only.*

### **Abnormal Lead Impedance (greater than 3500 Ohms or less than 250 Ohms)**

#### Troubleshooting During an Intraoperative Procedure

The goal of the following procedures is to ascertain if the abnormal lead impedance measurement is associated with the lead or with the RNS® Neurostimulator port to which the lead is connected.

1. Repeat the impedance measurements.
2. If the impedance remains abnormal, note the electrode label associated with the abnormal impedance
3. Reconnect leads in the same neurostimulator port.
  - Disconnect and reconnect the leads to the connector cover and neurostimulator according to the instructions in the relevant section of the system manual.
  - View the live ECoGs to verify that the signal is sufficient and without noise or artifacts.
  - Repeat impedance measurements.
4. If the impedance remains abnormal, note the electrode label associated with the abnormal impedance.
5. Place leads in the opposite neurostimulator port.

- Disconnect leads, place leads in the opposite connector cover ports, and reconnect the connector cover and neurostimulator according to the instructions in the relevant section of the system manual.
- Program the new lead information and montage and use the same electrode labels for the new lead configuration.
- View the live ECoGs to verify that the signal is sufficient and without noise or artifacts.
- Repeat impedance measurements.

*Note: If the abnormal impedance is associated with the same electrode label, then the problem may be with the lead.*

#### Depth lead - Impedance > 3500 Ohms

- The depth lead may be damaged and should be replaced. Refer to instructions in the relevant section of the system manual.

#### Depth lead - Impedance < 250 Ohms

- The depth lead may be damaged and should be replaced. Refer to the instructions in the relevant section of the system manual.

#### Cortical strip lead - Impedance > 3500 Ohms

- The high impedance may be due to air.
- Irrigate the area around the cortical strip lead and examine the geometry.
- Repeat impedance measurements.
- If the impedance remains abnormal, the cortical strip lead may be damaged and should be replaced. Refer to the instructions in the relevant section of the system manual.

#### Cortical strip lead - Impedance < 250 Ohms

- The cortical strip lead may be damaged and should be replaced. Refer to the instructions in the relevant section of the system manual.

*Note: If the abnormal impedance is not associated with the same electrode label, the problem may be with the neurostimulator or connector cover.*

#### 6. Replace the connector cover.

- Disconnect the leads from the connector cover and reconnect the leads to a new connector cover. Connect to the neurostimulator and troubleshoot according to the instructions in the relevant section of the system manual.
- View the live ECoGs to verify that the signal is sufficient and without noise or artifacts.
- Repeat impedance measurements.

#### 7. If the impedance remains abnormal, replace the neurostimulator. Refer to instructions in the relevant section of the system manual.

---

#### Troubleshooting During a Routine Follow-up

1. Repeat lead impedance measurements to verify abnormal lead impedance.
2. Take an image (X-ray or CT scan) of the implanted lead(s) and connector cover to discern the integrity of the lead.
  - **Lead Damage** – If the lead is damaged or fractured, it is recommended to abandon and replace the lead. Refer to the instructions in the relevant section of the system manual.
  - **Poor Connection** – If the lead is not completely installed in the connector cover, it is recommended to surgically revise the connection between the connector cover and lead. Refer to the instructions in the relevant section of the system manual.

*Note: It is normal for lead impedance measurements to fluctuate following the implant procedure due to the acute injury and healing processes of the brain tissue.*

*Note: Lead damage may not be immediately apparent from the live ECoGs. Using the **NOISE** ECoG capture trigger may be helpful in future troubleshooting techniques.*

### Insufficient Charge

Insufficient charge occurs when the neurostimulator is unable to fully deliver the programmed therapy. It may be due to high lead impedance or the neurostimulator configuration settings. If you receive an insufficient charge alert (see **Figure 12** and **Figure 13** on page 27) that cannot be explained by observed lead impedance changes, or if the first entries in the PDMS interrogation report event list show the “Programmed current” is higher than the “Lowest delivered” current, contact your NeuroPace Field Clinical Engineer. The NeuroPace Field Clinical Engineer will help you review the neurostimulator configuration settings to determine the cause. An example interrogation report is shown below.

The screenshot shows the Neurostim Settings interface. The 'Event List' tab is active, displaying a table of events. A red dashed box highlights the event at 13:36:15, which is a 'Subsequent Interrogation'. A red arrow points to this event with the text 'Select to open detailed report'. Below this, the 'Device Alerts' section is shown, with a yellow background indicating an 'Impedance Alert' and 'Therapy Amplitude Alert'. The alert text states: 'Insufficient charge was detected for electrode P2-1. Some therapies are being delivered below their programmed current levels. Review the detailed diagnostics to determine which therapies are impacted. Decrease the programmed Current or Pulse Width for the impacted therapies.' Below the alerts, the 'Event List' table is shown, detailing four bursts of stimulation. Each burst shows a programmed current of 5.0 mA and a lowest delivered current of 4.8 mA.

Date	Time	Duration	PGM/DTR	Report Type
03/29/2016	13:57:23		5000	Initial Interrogation
03/29/2016	13:57:23		5000	Electrode Impedance
03/29/2016	13:51:21		5000	Initial Interrogation
03/29/2016	13:51:21		5000	Electrode Impedance
03/29/2016	13:36:15		5000	Subsequent Interrogation
03/29/2016	13:34:54		5000	Programming
03/29/2016	13:33:00		5000	Initial Interrogation
03/29/2016	13:33:00		5000	Electrode Impedance

Device Alerts				
<b>Impedance Alert</b>	Insufficient charge was detected for electrode P2-1.			
<b>Therapy Amplitude Alert</b>	Some therapies are being delivered below their programmed current levels. Review the detailed diagnostics to determine which therapies are impacted. Decrease the programmed Current or Pulse Width for the impacted therapies.			

Event List				
Episode Sequence	Date and Time (US/Pacific)	Duration	Event Type	
-	Tue, Mar 29, 2016 13:36:14	0 seconds	Stim 1 Burst 1 Programmed current = 5.0 mA, Lowest delivered = 4.9 mA, Next = 4.8 mA	
-	Tue, Mar 29, 2016 13:36:14	0 seconds	Stim 2 Burst 1 Programmed current = 5.0 mA, Lowest delivered = 4.9 mA, Next = 4.8 mA	
-	Tue, Mar 29, 2016 13:36:14	0 seconds	Stim 3 Burst 1 Programmed current = 5.0 mA, Lowest delivered = 4.9 mA, Next = 4.8 mA	
-	Tue, Mar 29, 2016 13:36:14	0 seconds	Stim 4 Burst 1 Programmed current = 5.0 mA, Lowest delivered = 4.9 mA, Next = 4.8 mA	

Figure 82 Accessing an interrogation report that shows insufficient charge

### Noise, Artifacts, Poor Signal Displayed, or No Signal Displayed in Live ECoG

#### Troubleshooting During an Intraoperative Procedure

1. If no ECoG signal is seen, make sure the recording montage has been programmed.
2. If the signal is too high in amplitude or saturating, decrease the gain setting.
3. If the leads are positioned over the RNS<sup>®</sup> Neurostimulator, move them away from the neurostimulator.
4. Remove the connector cover from the RNS<sup>®</sup> Neurostimulator using the torque driver.
5. Flush the connector cover (with leads inserted) and the RNS<sup>®</sup> Neurostimulator connector area with saline.

6. Remove the leads from the connector cover. Clean the proximal end of the lead with saline and visually inspect that the lead end is free of excess blood or other tissue.
7. Reinsert the leads. Verify that they are fully inserted into the connector cover ports.
8. Place the connector cover back onto the RNS<sup>®</sup> Neurostimulator. Verify, once again, that the leads are fully inserted in the connector cover ports.
9. Secure the connector cover onto the RNS<sup>®</sup> Neurostimulator using the torque driver.
10. View the live ECoGs to verify that the signal is sufficient and free of noise or artifacts. Isolated artifacts may be the result of electrostatic discharge (ESD) / static electricity shocks to the tablet.
11. If the signal contains noise or artifacts, disconnect the AC adapter from the tablet and run on battery power. (Make sure the battery is charged before doing so.) Disconnect the network cable as well if it is connected.
12. If the signal is not sufficient or still contains noise or artifacts, measure the impedances. If the impedances are out of range, follow the instructions in the relevant section of the system manual.
13. If impedance measurements are normal, but the problem remains, try using a different tablet, if available.
14. If the problem persists, replace the neurostimulator. Refer to the relevant section of the system manual.

#### Troubleshooting During a Routine Follow-up

1. Reposition the wand over the RNS<sup>®</sup> Neurostimulator and interrogate again.
2. If the signal is not sufficient, follow the **Poor or No Communication Between the RNS<sup>®</sup> Neurostimulator and the RNS<sup>®</sup> Tablet** instructions in this section.
3. If the signal is not sufficient, measure the impedances. If the impedances are out of range, follow the instructions in the relevant section of the system manual.

#### **Poor or No Communication Between the RNS<sup>®</sup> Neurostimulator and the RNS<sup>®</sup> Tablet**

1. Confirm that the wand cable is inserted securely into the USB port on the tablet.
2. Confirm that the concave side of the wand faces the neurostimulator and that the wand is within approximately 1 inch of the neurostimulator.
3. Disconnect the AC adapter from the tablet and run on battery power. (Make sure the battery is charged before doing so.) Disconnect the network cable as well if it is connected.
4. Move electronic equipment that may be a source of interference or move away from such equipment if possible. (Turning electronic equipment on and off may help identify the source of any interference.)
  - Reposition the wand over the neurostimulator and interrogate.
  - View the live ECoGs to verify that the signal is sufficient and void of noise or artifacts.
5. Restart (turn OFF and back ON) the tablet. Attempt the interrogation again.
6. Try a different tablet, if available.

7. Try interrogating a different neurostimulator, if available, to see if the problem is with the neurostimulator.

#### **Tablet Does Not Turn On**

1. Charge the tablet for at least four (4) hours.
2. Press and hold the power button for four (4) seconds. After 2-3 seconds, the tablet beeps to indicate it is powering on. If the tablet does not turn on, follow these instructions again. If the tablet still does not start, contact NeuroPace for further assistance (see **Contacting NeuroPace** on page 5).

#### **Tablet Freezes or Does Not Turn Off**

1. Plug the tablet into a grounded power outlet.
2. Shut down the tablet: Press and hold down the power button for 11 seconds to shut down. Then release the power button and wait 10 seconds.
3. Restart the tablet: Press and hold down the power button for four (4) seconds. After 2-3 seconds, the tablet beeps to indicate it is powering on. If the tablet does not restart, follow these instructions again. If the tablet still does not start, contact NeuroPace for further assistance (see **Contacting NeuroPace** on page 5).

#### **Tablet Shuts Down**

1. Plug the tablet into a grounded power outlet.
2. Restart the tablet: Press and hold the tablet power button. After 2-3 seconds, the tablet beeps to indicate it is powering on. If the tablet does not restart, follow these instructions again. If the tablet still does not start, contact NeuroPace for further assistance (see **Contacting NeuroPace** on page 5).

#### **Impedance Measurement Was Rejected / Test Request Was Rejected**

##### Message

*“Impedance measurement was rejected by the neurostimulator”*

*“Test request was rejected by the neurostimulator”*

##### Issue

The neurostimulator cannot measure impedance or test stimulation (test therapy).

##### Possible Cause

- The neurostimulator may be delivering therapy. The system cannot measure impedance or test stimulation during therapy delivery.
- The neurostimulator may be detecting an episode. The system cannot measure impedance or test stimulation during episode detection.

##### Actions To Be Taken

1. Wait until therapy delivery completes or temporarily disable therapy delivery.
2. Wait until episode detection completes or temporarily disable detection.

## SPECIFICATIONS AND CHARACTERISTICS

### RNS<sup>®</sup> TABLET

<b>DIMENSIONS*</b>	Width: 29 cm Height: 21 cm Depth: 1 cm
<b>MATERIAL</b>	Commercial Materials
<b>WEIGHT*</b>	0.86 kg
<b>POWER SOURCE</b>	100 – 240 VAC, 1.7 A or internal rechargeable battery
<b>USB POWER SUPPLY</b>	5V, 500 mA
<b>OPERATING TEMPERATURE</b>	0 °C to 40 °C

\* Typical, approximate values. The values for your tablet may be different.

### WAND (MODEL W-02)

<b>DIMENSIONS (LENGTH X WIDTH X DEPTH)</b>	7" x 3.5" x 1.3" (18 cm x 9 cm x 3 cm)
<b>WEIGHT</b>	0.4 pounds (181 g)
<b>POWER SOURCE</b>	USB port of the tablet
<b>OPERATING CONDITIONS</b>	Temperature: 32 to 95 °F (0 to 35 °C) Humidity: 15 to 90%, non-condensing Atmospheric pressure: 700 to 1060 hPa
<b>MATERIAL</b>	ABS copolymer
<b>LEAST FAVORABLE WORKING CONDITIONS</b>	Wand output power and data rate vary with communication distance. Communication at a far distance (3 cm), indicated by a low signal level when using the wand, results in the slowest rate of transmission at the highest output power.
<b>STORAGE AND TRANSPORT TEMPERATURE</b>	32 to 140 °F (0 to 60 °C)
<b>EXPECTED SERVICE LIFE</b>	5 years

**TABLET WIRELESS**

<b>WIRELESS FUNCTION</b>	Transfer data between the Neurostimulator and the Patient Data Management System (PDMS)
<b>WIRELESS TECHNOLOGY TYPE</b>	Wi-Fi dual band 802.11n and 802.11ac 4G (fallback to 3G)
<b>OPERATING DISTANCE</b>	Varies - Wi-Fi and cellular range similar to other smartphones and tablets
<b>FREQUENCY BAND OF OPERATION</b>	Wi-Fi: 2.4 GHz or 5 GHz Cellular: 700, 1900, 1700, 2100 MHz
<b>INTENDED USE ENVIRONMENT</b>	Clinical setting only
<b>REQUIRED WIRELESS QUALITY OF SERVICE</b>	The requirements for quality of service vary depending on the clinical function. The tablet login screen displays the network status indicator on the lower right hand corner of the screen. The indicator is a signal strength symbol consistent with commercial tablet computers.  There are no requirements for timely data transmission. The tablet locally stores data until a connection to PDMS is available. Data are resent until they are successfully received.
<b>RECOMMENDED WIRELESS SECURITY</b>	Wi-Fi: WPA2

**RNS<sup>®</sup> SYSTEM WIRELESS**

<b>WIRELESS FUNCTION</b>	Transfer data between the neurostimulator and the programmer or remote monitor and wand: interrogation, programming and live ECoGs
<b>WIRELESS TECHNOLOGY TYPE</b>	Short range, low power inductive coil to coil telemetry
<b>INTENDED USE ENVIRONMENT</b>	Clinical setting and home environment
<b>OPERATING RANGE</b>	0 – 3 cm
<b>FREQUENCY BAND</b>	20 kHz – 50 kHz
<b>RECEIVE BANDWIDTH OF THE NEUROSTIMULATOR</b>	100 kHz
<b>RECEIVE BANDWIDTH OF THE WAND</b>	≥ 50 kHz
<b>NUMBER OF CHANNELS</b>	Single Channel
<b>MODULATION TYPE</b>	On/Off pulse amplitude modulation
<b>RF DATA FLOW CHARACTERISTICS</b>	Half duplex
<b>EFFECTIVE RADIATED POWER</b>	37.25 nW or less

**ELECTROMAGNETIC EMISSIONS AND IMMUNITY**

Electromagnetic interference (EMI) is a field of energy generated by equipment found in the home, work, medical, or public environments that is strong enough to interfere with neurostimulator function. The RNS<sup>®</sup> System is designed to be immune from common sources of electromagnetic interference. The most common sources of EMI are discussed in this section.

The neurostimulator is intended to sense electrical activity of the brain, detect activity of interest, deliver stimulation therapy, and communicate with a programmer. In addition, the neurostimulator is intended to operate autonomously, conserve battery life, check for proper connectivity to leads, and automatically recover from certain conditions.

Electromagnetic disturbances may be detected by the neurostimulator as noise or saturation and therefore suppress the ability of the neurostimulator to detect activity of interest during the exposure to the electromagnetic field. Conversely, electromagnetic disturbances may be detected as activity of interest and result in the delivery of programmed stimulation to the patient. Electromagnetic disturbances will not cause the neurostimulator to change modes or operating parameters. Electromagnetic disturbances will not cause the neurostimulator to exceed prescribed therapy limits or charge density limits. Electromagnetic disturbances can be expected to reduce the ability of the neurostimulator to communicate with the programmer. If this happens, refer to **Poor or No Communication Between the RNS® Neurostimulator and the RNS® Tablet** on page 102. The neurostimulator is expected to recover all intended functions following the removal of the electromagnetic disturbance.

### **Hospital or Medical Environments**

Patients should always inform healthcare personnel that they have an implanted RNS® System (and show their medical implant identification card) before any procedure is performed. Most diagnostic procedures, such as x-rays and ultrasounds, may be performed without affecting the RNS® System. However other diagnostic and therapeutic equipment with higher energy levels may interfere with the RNS® System. Refer to **Warnings and Cautions – Programmer** on page 6 for specific information.

### **Home, Work or Public Environments**

The patient should avoid or exercise caution when in the presence of the following potential sources of EMI that may affect the operation of the neurostimulator:

- Radiofrequency identification (RFID) sources
- Airport security and other surveillance systems
- Power lines and transmission towers
- Electric substations, power generators and large transformers
- Portable and mobile RF communications equipment
- Electric arc welding equipment
- Electric steel furnaces
- Electric induction heaters
- Electric fences
- Body fat measurement scales
- Jackhammers
- Stun guns

The following commonly used items should not affect the operation of the neurostimulator:

- Cell phones and Bluetooth devices

- Electric toothbrushes, electric shavers, and hair trimmers
- Microwave ovens
- Appliances such as washing machines, dryers, electric stoves, toasters, blenders, electric can openers, and food processors
- Electric blankets and heating pads
- Personal computers, electric typewriters, copiers, and fax machines
- Televisions, AM/FM radios, stereos, personal music players
- Vacuum cleaners and electric brooms

For additional information about devices that generate electromagnetic interference contact NeuroPace (see **Contacting NeuroPace** on page 5). If a patient suspects EMI is disrupting the operations of their neurostimulator, advise the patient to move away from the source of the EMI.

#### **Guidance and Manufacturer's Declaration**

Medical electrical equipment needs special precautions regarding EMC and needs to be installed and put into service according to EMC information provided. This declaration applies for the following devices:

- RNS® Neurostimulator, models RNS-300M and RNS-320
- RNS® Tablet, model 5000
- Wand, model W-02
- Remote Monitor, models DTR-300 and DTR-300-E, and 5100

The devices comply with IEC 60601-1-2, ISO 14708-3, and FCC 47 CFR Parts 2 and 15.

- Portable and mobile RF communications equipment can affect the device.
- This equipment/system may cause radio interference or may disrupt the operation of nearby equipment. The devices may be interfered with by other equipment, even if that other equipment complies with CISPR emission requirements. It may be necessary to take mitigation measures, such as re-orienting or relocating the devices or shielding their location.

#### **Emissions and Immunity Information**

The programmer with wand is designed for use in a medical environment by a trained healthcare professional. The remote monitor with wand is designed for use in the home by a patient. The devices

are intended for use in the electromagnetic environment specified below. The customer or user of the system should assure they are used in such an environment.

*Note: Unless otherwise indicated in the table footnotes, emissions testing information in the tables below apply to all of the devices addressed in this section as listed above.*

**Table 1. Guidance and manufacturer's declaration –  
electromagnetic emissions – for all equipment and systems**

Emissions test	Compliance	Electromagnetic environment – guidance
Conducted emissions (CISPR 11)	Class B, Group 1 150 kHz to 30 MHz	The RNS® System uses RF energy only for its internal function. Nearby electronic equipment may be affected.
RF emissions (CISPR 11)	Class B, Group 1 30 MHz to 1 GHz	
Harmonic emissions (IEC 61000-3-2)	Class A Device <sup>a</sup>	The RNS® System is suitable for use in all establishments, including domestic establishments and those directly connected to the public low-voltage power supply network that supplies buildings used for domestic purposes.
Voltage fluctuations / flicker emissions (IEC 61000-3-3)	Limits per Clause 5 of the Standard <sup>a</sup>	

- <sup>a</sup>. Tablet (model 5000), Remote Monitor (model 5100), with Wand (model W-02) tested for harmonic emissions and flicker. Other products excluded from harmonic emissions and flicker testing.

**Table 2. Guidance and manufacturer's declaration –  
electromagnetic immunity – for all equipment and systems**

Immunity test	Compliance level	Electromagnetic environment – guidance
Electrostatic discharge (ESD) (IEC 61000-4-2)	±2, 4, 6, 8kV contact discharge <sup>a</sup> ± 2, 4, 8, 15kV air discharge <sup>a</sup>	Floors should be wood, concrete or ceramic tile. If floors are covered with synthetic material, the relative humidity should be at least 30%.
Electrical fast transient / burst (IEC 61000-4-4)	± 2 kV for power supply lines ± 1 kV for input / output lines <sup>b</sup>	Mains power quality should be that of a typical commercial or hospital environment.
Surge (IEC 61000-4-5)	± 1 kV line(s) to line(s) ± 2 kV line(s) to earth <sup>c</sup>	
Voltage dips, short interruptions and voltage variations on power supply input lines (IEC 61000-4-11)	0% U <sub>T</sub> 0.5 cycle 0% U <sub>T</sub> 1 cycle <sup>d</sup> 40% U <sub>T</sub> 5 cycle <sup>d</sup> 70% U <sub>T</sub> 25 cycles 0% U <sub>T</sub> 5 Sec	If the user of the programmer and wand requires continued operation during power mains interruptions, it is recommended that the programmer and wand be powered from an uninterruptible power supply or a battery.
Magnetic immunity (IEC 61000-4-8)	3, 30 <sup>e</sup> A/m	

<sup>a</sup> Immunity to ESD tested to ±8 kV contact and ±15 kV air with Tablet (model 5000), Remote Monitor (model 5100), and Wand (model W-02).


<sup>b</sup> Immunity to electrical fast transients on I/O lines tested with Tablet (model 5000), Remote Monitor (model 5100), and Wand (model W-02).

<sup>c</sup> Immunity to surge line to earth tested with Programmer (model PGM-300) and Remote Monitor (model DTR-300-E).

<sup>d</sup> Immunity to voltage dips with compliance to 0% U<sub>T</sub> 1 cycle for Tablet (model 5000), Remote Monitor (model 5100), and Wand (model W-02) and to 40% U<sub>T</sub> 5 cycle for Programmer (model PGM-300) and Remote Monitor (model DTR-300-E).

<sup>e</sup> Magnetic immunity tested with Tablet (model 5000), Remote Monitor (model 5100), and Wand (model W-02) to 30 A/m.

**Table 3. Guidance and manufacturer’s declaration – electromagnetic immunity – for equipment and systems that are not life supporting**

Immunity Test	Compliance Level	Electromagnetic environment – guidance
Conducted RF (IEC 61000-4-6)	3 Vrms 150 KHz to 80 MHz  6 Vrms ISM bands <sup>a</sup>	Portable and mobile RF communications equipment should be used no closer to any part of the RNS <sup>®</sup> System, including cables, than the recommended separation distance calculated from the equation applicable to the frequency of the transmitter.
Radiated RF (IEC 61000-4-3)	3, 10, 20 V/m 80 MHz to 2.7 GHz <sup>e</sup>	<p><b>Recommended separation distance</b> <sup>b, c</sup></p> <p><math>d = 1.17\sqrt{P}</math> (80 MHz to 800MHz)</p> <p><math>d = 2.33\sqrt{P}</math> (800 MHz to 2.7 GHz)</p> <p>Where P is the maximum output power rating of the transmitter in watts (W) according to the transmitter manufacturer and d is the recommended separation distance in meters (m).</p> <p>Field strengths from fixed RF transmitters, as determined by an electromagnetic site survey<sup>d</sup>, should be less than the compliance level in each frequency range. Interference may occur in the vicinity of equipment marked with the following symbol:</p> 

- <sup>a</sup> Conducted immunity of the Tablet (model 5000), Remote Monitor (model 5100), and Wand (model W-02) compliant to 6 V/m in the ISM bands.
- <sup>b</sup> Separation distance relevant to Programmer (model PGM-300) and Remote Monitor (model DTR-300). At 80 MHz and 800 MHz, the higher frequency range applies.
- <sup>c</sup> These guidelines may not apply in all situations. Electromagnetic propagation is affected by absorption and reflection from structures, objects and people.
- <sup>d</sup> Field strengths from fixed transmitters, such as base stations for radio (cellular/cordless) telephones and land mobile radios, amateur radio, AM and FM radio broadcast and TV broadcast cannot be predicted theoretically with accuracy. To assess the electromagnetic environment due to fixed RF transmitter, an electromagnetic site survey should be considered. If the measured field strength in the location in which the RNS<sup>®</sup> System is used exceeds the applicable RF compliance level above, the RNS<sup>®</sup> System should be observed to verify normal operation. If abnormal performance is observed, additional measures may be necessary, such as re-orienting or relocating the RNS<sup>®</sup> System.
- <sup>e</sup> Radiated immunity of the Programmer (model PGM-300), Remote Monitor (model DTR-300-E) compliant to 3 V/m up to 2.5 GHz. Tablet (model 5000), Remote Monitor (model 5100) and Wand (model W-02) compliant to 10 V/m to 2.7 GHz and spot frequencies with pulse modulation and to 20 V/m in the communication passband. Spot frequencies tested are: 385 MHz, 450 MHz, 710 MHz, 745 MHz, 780 MHz, 810 MHz, 870 MHz, 930 MHz, 1.720 GHz, 1.845 GHz, 1.970 GHz, 2.450 GHz, 5.240 GHz, 5.500 GHz, 5.785 GHz.

**Table 4. Recommended separation distances between portable and mobile RF communications equipment and the RNS® System<sup>a, b, c</sup>**

Rated maximum output power of transmitter W	Separation distance according to frequency of transmitter (m)		
	150 kHz to 80 MHz	80 MHz to 800 MHz	800 MHz to 2.5 GHz
	$d = 1.17\sqrt{P}$	$d = 1.17\sqrt{P}$	$d = 2.33\sqrt{P}$
0.01	0.12	0.12	0.23
0.1	0.37	0.37	0.74
1	1.17	1.17	2.33
10	3.69	3.69	7.38
100	11.67	11.67	23.33

- <sup>a</sup> All separation distances relevant to Programmer (model PGM-300) and Remote Monitor (model DTR-300). At 80 MHz and 800 MHz, the higher frequency range applies.
- <sup>b</sup> These guidelines may not apply in all situations. Electromagnetic propagation is affected by absorption and reflection from structures, objects and people.
- <sup>c</sup> For transmitter rated at a maximum output power not listed above, the recommended separation distance of  $d$  in meters (m) can be estimated using the equation applicable to the frequency of the transmitter, where  $P$  is the maximum output power rating of the transmitter in watts (W) according to the transmitter manufacturer.

## GLOSSARY

**Adapt Channel.** The adapt channel is an advanced responsive therapy setting. The neurostimulator will monitor this channel from which to calculate the adaptive stimulation frequency. This channel is used for all adaptive bursts.

**Adapt Min Amplitude.** The percentage of the detected signal amplitude to be used as the minimum therapy amplitude.

**Adaptation.** The neurostimulator may be programmed to deliver the pulse interval for a responsive therapy burst by adapting to the electrographic signal by a selected percentage.

**Anode.** The positive pole of an electrode selected for stimulation.

**Area Detection Tool.** The area detection tool measures the area under the curve of an ECoG signal.

**Asynchronous Pulse.** Delivery of the first pulse in a burst independent of the ECoG activity.

**Bandpass Detection Tool.** The bandpass detection tool measures the approximate frequency of the signal based on the duration and amplitude of waveform segments.

**Battery Measurement.** The neurostimulator battery voltage may be measured interactively through the programmer.

**Burr Hole.** Hole made in the skull used for the insertion and securing of implanted cortical and/or depth leads.

**Burr Hole Cap.** The burr hole cap is intended to secure the leads in relation to the cranium.

**Burr Hole Cover.** The burr hole cover is intended to secure the leads to the burr hole cap.

**Burst.** An individually programmed group of one to many pulse(s) of current delivered by the neurostimulator.

**Burst Duration.** The amount of time during which a burst will be delivered by the neurostimulator.

**Burst 1.** The first burst of stimulation delivered within an individual responsive therapy. This burst may be delivered asynchronously or synchronously.

**Burst 2.** The second burst of stimulation delivered within an individual responsive therapy. This burst may be programmed ON or OFF for each therapy and will always be delivered asynchronously following Burst 1 of the therapy if programmed ON.

**Can.** "Can" is used to describe the neurostimulator titanium body. The can may be used as either an anode (+) or cathode (–) in a stimulation pathway.

**Cathode.** The negative pole of an electrode selected for stimulation.

**Channel.** The amplifier channel of electrodes selected to detect ECoG activity.

**Connector Cover.** The connector cover is intended to secure the proximal lead contacts and lead strain relief to the body of the neurostimulator.

**Connector Cover Port.** The connector cover ports contain the point of contact between the proximal end of the lead(s) and the neurostimulator. The connector cover contains two (2) ports, one for each lead.

**Connector Plug.** The connector plugs are used to fill any ports on the connector head of the neurostimulator that are not in use.

**Cortical Strip Lead.** The NeuroPace® Cortical Strip Lead lies on the surface of the brain (cortex) and can detect the electrical activity of the brain and deliver stimulation.

**Cranial Prosthesis.** The cranial prosthesis is intended to occupy the vacant craniectomy after the neurostimulator has been explanted.

**Craniectomy.** Defect formed in the skull in order to implant the neurostimulator.

**Craniectomy Template.** The craniectomy template is intended to be used as a pattern to mark and delineate the shape of the ferrule on the skull prior to making the craniectomy.

**Current.** The amplitude of current that will be delivered in each phase of a current pulse.

**Delay.** A programmed delay in the delivery of the first pulse of a burst, measured from the time of synchronizing to a signal peak.

**Default Therapy Frequency.** The default therapy frequency is an advanced setting available for each responsive therapy burst. For an adaptive therapy burst (Adaptation = ON), if the calculated stimulation frequency does not fall between the programmed min and max frequencies, then the stimulation is delivered at the default therapy frequency.

**Delay.** A programmed delay in the delivery of the first pulse of a burst, measured from the time of synchronizing to a signal peak.

**Depth Lead.** The NeuroPace® Depth Lead is implanted into the brain and can detect the electrical activity of the brain and deliver stimulation.

**Detection Settings.** Settings that combine patterns and detection tool settings in order to detect activity.

**Detection Tools.** There are three (3) types of detection tools selectable for Pattern A or Pattern B detectors. The detection tools are: the bandpass tool, power change tool (also known as the line length tool), and area tool.

**ECoG.** Electrocorticogram. Electrical activity derived directly from the cerebral cortex. Also used to describe the neurostimulator or programmer stored record of this activity (e.g. "ECoG record").

**ECoG Activity.** ECoG activity refers to activity which is detected by the neurostimulator using one of the event detectors.

**ECoG Trigger.** The type of neurostimulator activity selected by the user to result in the capture of an ECoG record if the activity occurs.

**Elective Replacement Indicator (ERI).** The ERI indicator is displayed on the programmer to notify the user that the neurostimulator is approximately three months prior to end-of-service (EOS). Neurostimulator elective replacement is suggested at a battery voltage equal to the ERI.

**End-Of-Service (EOS).** End of service is the point in service at which the battery level is still sufficient to allow operation, however some features may be lost.

**Estimated Charge Density.** The charge density of a selected and/or programmed stimulation is estimated by the programmer. Charge densities greater than 25  $\mu\text{C}/\text{sq cm}$  are not allowed to be selected or programmed into the neurostimulator.

**Event.** Activity detected by the neurostimulator. Events are considered any of the following: long episodes, pattern A, pattern B, responsive therapy, noise or saturation.

**Ferrule.** The ferrule is intended to be installed in a craniectomy to secure and mechanically support the neurostimulator in the cranium.

**Ferrule Clamp.** The ferrule clamp is used to secure the neurostimulator to the ferrule.

**Frequency.** The frequency is the rate at which pulses are delivered which is expressed in Hz (pulses/second).

**Gain.** ECoG signal amplification on one channel of the neurostimulator.

**Impedance Measurement.** The opposition of current flow between electrodes as determined by measuring the voltage (Ohms) resulting from the delivery of a current pulse. A current pulse must be applied to the patient in order to obtain this measurement.

**Interrogate.** The act of retrieving stored data and settings from the neurostimulator using the programmer.

**Lead Cap.** The lead cap is intended to physically protect the proximal ends of implanted leads that are not connected to the neurostimulator.

**Lead ID.** Numerical and/or alpha characters assigned to a lead to describe its anatomical location.

**Lead Strain Relief.** The lead strain relief is intended to mechanically support the proximal ends of the lead at their exit point from the neurostimulator.

**Line Length Detection Tool:** See Power Change Detection Tool. The line length detection tool (also known as the power change detection tool) performs an estimate of the length dimension of a signal related to the complexity of a signal.

**Live ECoG.** ECoG data viewed in real-time through the programmer.

**Long Episode.** Initiate ECoG storage when a detected episode continues beyond a preset duration.

**Magnet.** The magnet can be used by a patient to mark a clinical seizure, and depending on how the physician programs the neurostimulator, to trigger electrocorticographic (ECoG) storage and withhold therapy.

**Max Therapy Frequency.** The max therapy frequency is an advanced setting available for each responsive therapy burst. For an adaptive therapy burst (Adaptation = ON), the max therapy frequency specifies the maximum stimulation frequency. If the calculated stimulation frequency does not fall between the programmed min and max frequencies, then the stimulation is delivered at the default therapy frequency.

**Min Therapy Frequency.** The min therapy frequency is an advanced setting available for each responsive therapy burst. For an adaptive therapy burst (Adaptation = ON), the min therapy frequency specifies the minimum stimulation frequency. If the calculated stimulation frequency does not fall between the programmed min and max frequencies, then the stimulation is delivered at the default therapy frequency.

**Montage.** Collective term used to describe the assignment of electrode labels and gain settings to the amplifier channels.

**Neurostim Info.** Programmer display of measurements of the neurostimulator lead impedances and battery voltage.

**Neurostimulator.** The RNS<sup>®</sup> Neurostimulator is an implantable, battery powered, microprocessor controlled device that can amplify and analyze the patient's electrocorticographic activity, detect activity from intracranial electrodes and deliver a short train of current pulses to the brain to attempt to interrupt the detected activity.

**Noise.** 1. An event detector that identifies 60 Hz noise from selected detection channels. 2. Environmental interference in the telemetry between the neurostimulator and wand/programmer.

**Overwritten.** Once the memory for ECoG or diagnostics is full, the neurostimulator will store new data by overwriting the oldest ECoG records or diagnostics. Reserved ECoGs are only overwritten by newer ECoGs of the same ECoG capture trigger type.

**Patient Data Management System (PDMS).** The NeuroPace® Patient Data Management System is a secure database that provides a means for a clinician to review information that has been transmitted by the programmer and the remote monitor.

**Pattern Detection.** Analysis of detection settings using the programmer detection tools and retrieved neurostimulator ECoG records.

**Patterns.** Patterns (pattern A and pattern B) use a collection of detection tools to classify electrographic activity. Patterns A1 and B1 apply to the first chosen channel and Patterns A2 and B2 to the second chosen channel.

**Post-Episode Interval.** Responsive therapies will be DISABLED for this period of time after detecting the end of an episode.

**Power Change Detection Tool.** The power change detection tool (also known as the line length detection tool) performs an estimate of the length dimension of a signal related to the complexity of a signal.

**Programmer.** The programmer provides the clinician with a user interface to select and download operating parameters to the neurostimulator for detection and responsive stimulation settings, to view live ECoG signals, to test the RNS® System integrity, and to upload data and diagnostic information from the neurostimulator for viewing.

**Programming.** Using the programmer to program settings into the neurostimulator.

**Programming set.** A programming set includes the settings for detection, stimulation, and ECoG capture.

**Pulse.** A biphasic waveform of electrical stimulation delivered by the neurostimulator.

**Pulse-Width Per Phase (PW).** Duration of a single phase within a biphasic pulse, measured in milliseconds.

**Reset.** When the neurostimulator resets, detection and all therapies are disabled, and the neurostimulator stops storing ECoGs and diagnostics. (However, events prior to reset will be saved.) If you interrogate a neurostimulator that has reset, the programmer displays one or more alerts that describe the cause of the reset. When the type of reset is recoverable, the programmer displays instructions to recover, which typically guide you to reprogram the neurostimulator. If the reset is not recoverable, or if recovery is unsuccessful, note the cause of the reset and contact NeuroPace (see **Contacting NeuroPace** on page 5).

**Responsive Stimulation.** Electrical stimulation output to cortical tissue by the RNS® Neurostimulator in response to a detection.

**Saturation Event Detector.** Saturation occurs when an input signal exceeds the dynamic range of a particular channel. The neurostimulator incorporates a saturation detector to reduce occurrences of detecting saturation as a neurological event.

**Scheduled Storage.** A selectable neurostimulator function that causes the neurostimulator to capture an ECoG at the desired time(s) of day.

**SimpleStart Feature.** This feature allows the physician to easily begin the process of defining detection parameters by touching or clicking on the location in the ECoG where the physician would like detection to occur.

**Simulate Performance.** Simulation uses the programmer to test a proposed set of detection settings with retrieved ECoGs. The simulation will generate markers, simulating how the neurostimulator may detect if those settings are programmed into the neurostimulator.

**Start Time.** Scheduled storage setting controlling the time(s) at which ECoG capture will be triggered.

**Stereotactic Frame.** A medical device that is attached to the patient's head and provides a three-dimensional frame of reference for accurate implantation of depth leads.

**Stereotactic Surgery.** Surgery in which a system of three-dimensional coordinates is used to locate the site to be operated on.

**Stim Pathway.** Collective term describing the anodes [+] and cathodes [-] selected for a burst.

**Stop Gauge.** The stop gauge is placed on a depth lead prior to implantation to indicate the appropriate depth of its insertion.

**Stylet.** Support wire contained in both the cortical strip and depth leads. The stylet is removed after proper lead placement has been achieved.

**Suture Sleeve.** The suture sleeve is intended to protect the lead body at the point at which the lead is sutured to subcutaneous tissue to immobilize it and prevent its dislodgement while chronically implanted.

**Synch Channel.** The neurostimulator will monitor this channel for ECoG signal peaks to calculate synchronous delivery timing. One channel will be used for all bursts selected to have synchronous pulse delivery.

**Synchronization.** Delivering the first pulse in a burst or after a first pulse delay (synchronous) from a peak in an ECoG signal.

**Technical Parameters.** Option to configure detection using all detection parameters.

**Telemetry.** Communication between the neurostimulator and the programmer.

**Test Stimulation.** A stimulation that is configured and delivered in real-time using a programmer.

**Therapy Frequency Multiplier.** Therapy frequency multiplier is an advanced responsive therapy setting. The therapy frequency multiplier specifies the ratio of the stimulation frequency to the sensed signal frequency.

**Therapy Limit Per Day.** Responsive therapy delivery will be DISABLED for the remainder of the day after the programmed number of responsive therapies has been delivered.

**Therapy Sequence.** Responsive therapy is delivered as a therapy sequence of up to 5 individually configured sequential therapies (electrical stimulation) in response to each detected episode.

**Tunneling.** Part of the implant procedure during which the proximal end of an implanted lead is tunneled from the burr hole location to the neurostimulator implant location to achieve a lead/neurostimulator connection.

**Tunneling Tool.** The cranial tunneling tool is intended to tunnel implanted leads from their point of exit from the cranium through a sub-galeal pathway to the implanted neurostimulator location.

**INDEX**

- 2-channel detection set, 56
- Abnormal Lead Impedance**, 28, 98
- About this manual, ii
- ACCEPT CHANGES**, 85
- Access PDMS, 10
- Activity histogram, 30
- Activity screen, 29, 96
- ADAPT CHANNEL**, 83
- ADAPT MIN AMPLITUDE**, 83
- ADAPTATION**, 83
- Adaptive Therapy**, 82
- ADV** (Advanced) column, 33
- ADV SETTINGS**, 70
- Advanced Controls, 61
- ADVANCED SETTINGS** dialog, 61
- Advanced Settings—therapy, 82
- Afterdischarge Activity—caution, 8, 85, 97
- AMPLITUDE**, 67, 68
- AMPLITUDE (%)** slider, 56, 61
- AREA**, 61, 63
- Area Detection Tool, 70
- Artifacts, 41, 98, 99, 101, 102
- ASSIGN CATEGORY** field, 36
- Assign Channels**, 41
- BANDPASS**, 61, 63
- Bandpass detection tool, 68
- Bandpass Detection Tool, 69
- Battery Measurement, 28
- Battery Voltage, 27
- burst, 79
- BURST DURATION**, 80
- bursts or burst, 77
- Capture Duration**, 45
- Capture ECoGs, 43
- Capture Triggers**, 45
- CAPTURE WINDOW** field, 37, 45
- CATEGORIES**, 36
- CHANGE CHANNEL** button, 56
- CHANGE DETECTION** screen, 96
- CHANGE ECoG CAPTURE** screen, 44
- CHANGE RECORDING MONTAGE**, 25, 40
- CHANNEL(S)** (**CH 1** through **CH 4**), 45
- CLEAR button on DEFINE PATTERNS dialog**, 56, 60
- Clinical Response and recommended therapy modifications, 87
- Computerized Tomography (CT), 100
- CONFIGURE CHANNELS** area, 45
- Configure Detection Settings**, 20, 37, 49, 96, 97
- Configure Responsive Therapy, 78
- configuring detection has three phases, 49
- Connect to the Internet**, 10, 11, 29, 35, 71, 98
- Connectivity Problems, 98
- Contacting NeuroPace, 5
- CONTINUE button**, 52
- Create the Recording Montage, 38
- Creating the Montage, 39
- CURRENT**, 41, 80
- Customize Detection, 58
- date range, 36
- Default Programming Set**, 49, 50
- DEFAULT THERAPY FREQUENCY**, 83

- 
- Define and Modify Detection Settings, 49
  - Define Detection Settings, 53
  - DEFINE PATTERNS** dialog, 55, 60
  - DELAY**, 84
  - DETECT** slider, 56, 61
  - Detection parameters, 56, 60
  - detection parameters affect sensitivity, 56
  - Detection Phase 1**, 49, 50
  - Detection Phase 2, 53
  - Detection Phase 3, 58
  - DETECTION SETTINGS**—share, 72
  - Detection Tools and Detectors, 64
  - Detector Power Change, 65
  - Detector Spike Activity, 68
  - Device Description, 4
  - DURATION**, 67, 68
  - DURATION** area, 37, 45
  - DURATION** slider, 56, 61
  - ECoG
    - Artifact, 41
    - Real-time, 97
    - Records, 97
  - ECoG Capture, 43
  - ECoG CAPTURE** screen, 37, 44, 96
  - ECoG Capture Settings—Initial, 46
  - ECoG Capture Settings—Review, 48
  - ECoG LIBRARY** screen, 96
  - ECoG Library Screen, 35
  - ECoG Records, 35
  - ECoG, Artifacts, 101
  - ECoG, Live, 101
  - ECoGs—Live, 37, 41
  - Electrode 1 is most distal, 39
  - Electrode Impedance, 27
  - electrodes numbered 1 through 4, 39
  - Electromagnetic Emissions and Immunity, 105
  - Emissions and Immunity Information, 107
  - Enable Therapy: Review & Program, 85
  - EPOCHS - PROGRAMMING**, 30
  - ESTIMATED CHARGE DENSITY**, 80
  - EVENT LIST**, 34
  - FAVORITES**, 36
  - FCC Information, iii
  - FLAGS**, 30
  - FREQUENCY**, 80
  - FROM** and **To** fields, 36
  - Functionality when Not Connected to PDMS, 11
  - GAIN**, 36, 41
  - Glossary, 112
  - Heating—caution, 8
  - HIDE button on DEFINE PATTERNS dialog**, 56, 60
  - hide the simulation, 60
  - Home Screen, 22
  - Identifying Ports, Leads and Electrodes on the Neurostimulator, 38
  - Impedance**, 28, 98
  - Impedance measurement, 27, 103
  - impedance significance, 28
  - IMPLANTS**, 30
  - Incompatibility of Programmer with Other Medical Devices—caution, 8
  - Initial detection settings, 50
  - Initial ECoG Capture Settings, 46
  - Initial Responsive Therapy Settings, 86
  - Insufficient Charge, 101
  - Interference, iii, 20, 101, 102, 107, 110
  - Interference, RFID—warning, 7

- Interference—caution, 8
- Internet connection, 11, 29, 35, 71, 98
- Interrogation, 19
- INTERVAL**, 41
- LAST PROGRAMMED** date, 25
- Lead damage, 100
- Lead Type**, 40
- LINE LENGTH**, 56, 61, 63
- Live ECoG, 101
- Live ECoG artifact—caution, 7
- Live ECoGs Screen, 37
- LOG IN** screen, 18
- Log In to the PDMS, 18
- Login overview, 10
- Login to the Patient Data Management System (PDMS)**, 10
- Login to the RNS® Tablet, 14
- LONG EPISODE** trigger, 45
- lower parameter values result in greater sensitivity, 56
- MAGNET**, 45, 48
- MAGNET SWIPE**, 30
- MAGNET THERAPY WITHHOLDING**, 81
- MAGNET** trigger, 45
- MAX THERAPY FREQUENCY**, 83
- MAXIMUM FREQUENCY**, 67, 68
- MEASURED BATTERY VOLTAGE**, 25
- MIN THERAPY FREQUENCY**, 83
- MINIMUM FREQUENCY**, 67, 68
- Mobile Broadband Works Automatically, 12
- MODEL**, 25
- MODIFY** buttons (**A1 & A2**, **B1 & B2**), 54
- Modify Detection Settings, 49
- Montage—Create, 38
- MORE CONTROLS** button, 56
- Network Connectivity Problems, 98
- NETWORKS** panel, 12
- NeuroPace components—warning, 7
- NeuroPace Update Center, 15
- NEUROSTIM EVENTS**, 30
- Neurostim Info Screen, 24
- Neurostimulator Interrogate, 19
- Neurostimulator Wireless Specifications, 105
- Neurostimulator, Configure Detection, 49
- Neurostimulator—Capture ECoGs, 43
- Neurostimulator—Initial Montage Settings, 41
- Noise, 20, 101
- NOISE** trigger, 46
- Noise—caution, 8
- OFFICE INTERROGATION**, 30
- ON/OFF** switch, 45
- Optional Advanced Settings—therapy, 82
- OPTIONS** area, 81
- Overview of Responsive Therapy, 77
- parameter values to the right of sliders, 56
- parameters—detection, 56, 60
- Patient & Neurostim Info, 95
- Patient Follow-Up, 97
- PATIENT HOME** screen, 93
- Patient List on Tablet and PDMS**, 10, 91
- PATIENT LIST** screen, 93
- PATTERN A DETECTION** trigger, 46
- PATTERN B DETECTION** trigger, 46
- PATTERNS A1 & B1**, 54, 59
- PATTERNS A2 & B2**, 54, 59
- PDMS login, 10, 18
- PDMS, access Internet, 10

- PDMS, Internet connection, 10
- Phase 1: Select a Default Programming Set upon First Use, 50
- Phase 2: Define Detection Settings, 53
- Phase 3: Customize Detection, 58
- Placement of the Programmer Power Cords—caution, 8
- Poor Connection of a lead**, 100
- port #1 and #2 locations, 38
- PORT #1** and **PORT #2**, 25
- PORT #1** and **PORT #2—IDENTIFYING**, 38
- Portable Radio Frequency (RF) Communications Equipment—warning, 7
- Post-Episode Interval, 84
- POST-EPISODE** trigger, 46
- Potential Shock—warning, 6
- POWER CHANGE**, 56, 61, 63
- Power Change Detector, 65
- Power On the Tablet, 10
- Products and Accessories, 4
- Program Neurostimulator, 41, 47
- Program RNS, 42, 48, 51, 86, 90
- Programmer Failure—caution, 8
- Programmer login, 14
- Programming, 96
- programming epoch, 29
- PROGRAMMING** screen, 50
- Programming set, 32
- PW PER PHASE**, 80
- Recommendation for Review of Initial ECoG Capture Settings, 48
- Recommended Initial ECoG Capture Settings, 46
- Recommended Initial Montage Settings, 41
- Recommended Initial Responsive Therapy Settings, 86
- Recommended Therapy Modifications After Observing Clinical Response, 87
- Recording Montage, 38
- REPORT TYPES**, 34
- Request rejected message, 103
- RESERVE SPACE** column, 46
- Responsive Therapy, 77
- RESPONSIVE THERAPY** trigger, 46
- Review of Initial ECoG Capture Settings, 48
- RFID Interference—warning, 7
- RHYTHMIC ACTIVITY**, 56, 61, 69
- Rhythmic Activity Detector, 67
- RNS® Neurostimulator Programming, 10
- RNS® Tablet Instructions, 10
- RNS® Tablet Kit Model 5001, 4
- S/N, serial number**, 25
- SATURATION** trigger, 46
- Save Advanced Settings**, 84
- SCHEDULED STORAGE** trigger, 45
- Security and Electronic Tracking Systems—warning, 7
- Selecting ECoG Capture Settings, 43
- sensitivity, 56
- SENSITIVITY (%)** slider, 56, 61
- serial number of tablet**, 25
- Set Capture Duration**, 45
- Set Capture Triggers**, 45
- Set Gain**, 41
- SHARE** button, 72
- signal level, 20
- signal quality, 20
- Significance of Battery Voltage, 28

- 
- Significance of Impedance, 28
  - SIMULATE** button, 54, 60
  - Specifications, 104
  - SPIKE ACTIVITY**, 56, 61, 69
  - Spike Activity Detector, 68
  - Start screen, 17, 74
  - Steps to Connect to a Wi-Fi Network, 12
  - STIM 1** through **STIM 5**, 79
  - STIMULATION** button, 79
  - STIMULATION** screen, 79, 96
  - Stimulation testing, 84
  - STOP/STORE**, 37
  - SYNCH CHANNEL**, 83
  - SYNCH MIN AMPLITUDE**, 83
  - SYNCH SLOPE**, 84
  - SYNCHRONIZATION**, 83
  - Synchronized Therapy**, 83
  - Tablet Does Not Turn On, 103
  - Tablet Freezes, 103
  - Tablet Instructions, 10
  - Tablet login, 14
  - Tablet Shuts Down, 103
  - Tablet software updates, 15
  - Tablet Specifications, 104
  - Tablet Wireless Specifications, 105
  - TECHNICAL PARAMETERS**, 61, 63
  - Test Stimulation Before Enabling, 84
  - TEST STIMULATION** screen, 84
  - Therapy Configuration, 78
  - THERAPY FREQUENCY MULTIPLIER**, 83
  - Therapy limit per day, 80
  - THERAPY LIMIT PER DAY**, 80
  - THERAPY LIMIT RESET TIME**, 81
  - Therapy Modifications, 87, 90
  - Therapy or Stimulation, 77
  - Therapy Settings—initial, 86
  - three phases of detection, 49
  - TIME**, 41
  - TRIGGERS**, 36, 45
  - Troubleshooting, 98
  - Troubleshooting During a Routine Follow-up, 100
  - Troubleshooting During an Intraoperative Procedure, 98
  - Troubleshooting Neurostimulator to Tablet Communication, 102
  - Troubleshooting, ECoGs, 101
  - Typographic conventions, 5
  - Update Center, 15
  - Update Options, 15
  - Update Types, 15
  - USB port, 19
  - Using the Define Patterns Dialog, 55
  - wand, 19
  - Warnings and Cautions – Programmer, 6
  - Wi-Fi connection, 11, 29, 35, 71, 98
  - WIRELESS SIGNAL** button, 23
  - X-ray, 100
  - ZOOM** in, 36

NeuroPace, Inc.  
455 N. Bernardo Ave.  
Mountain View, CA 94043

Customer Support: 1-866-726-3876  
(Toll Free in the US)  
Fax: 650-237-2855  
Website: [www.NeuroPace.com](http://www.NeuroPace.com)

